

SA-H101W
Winchester/Dual Floppy
Mounting Chassis
Installation

SA-H101W
Winchester/Dual Floppy
Mounting Chassis
Installation

Copyright © Sigma Information Systems

Anaheim, California - December 1982

SA-H101W

INSTALLATION

CONTENTS

General Description.....	1
Unpacking and Inspection.....	2
Power Checkout.....	3
Floppy Drives Installation.....	5
Winchester Drive Installation.....	6
Cabling.....	8
Mounting Sleeve Installation.....	9
Appendix - Power Supply Schematic.....	11

FIGURES

1	SA-H101W Chassis.....	1
2	DC Power Connectors.....	3
3	AC Power Configuration.....	4
4	Installing First Floppy Drive.....	5
5	Installing Second Floppy Drive.....	6
6	Winchester Drive/Formatter Installation.....	7
7	Winchester Drive/Formatter Cable Connections.....	8
8	Mounting Sleeve Installation.....	9
Appendix	Power Supply Schematic.....	11

SA-H101W

INSTALLATION

GENERAL DESCRIPTION

The SA-H101W is a 5.25" chassis with mounting space and power for a 5 1/4" winchester drive and two 8" slimline floppy drives. The front panel provides floppy drive access and the power supply allows convenient conversion between 115VAC and 230VAC. A mounting sleeve provides convenient installation into a standard 19" rack. The basic SA-H101W chassis (without mounting sleeve) is shown in Figure 1.

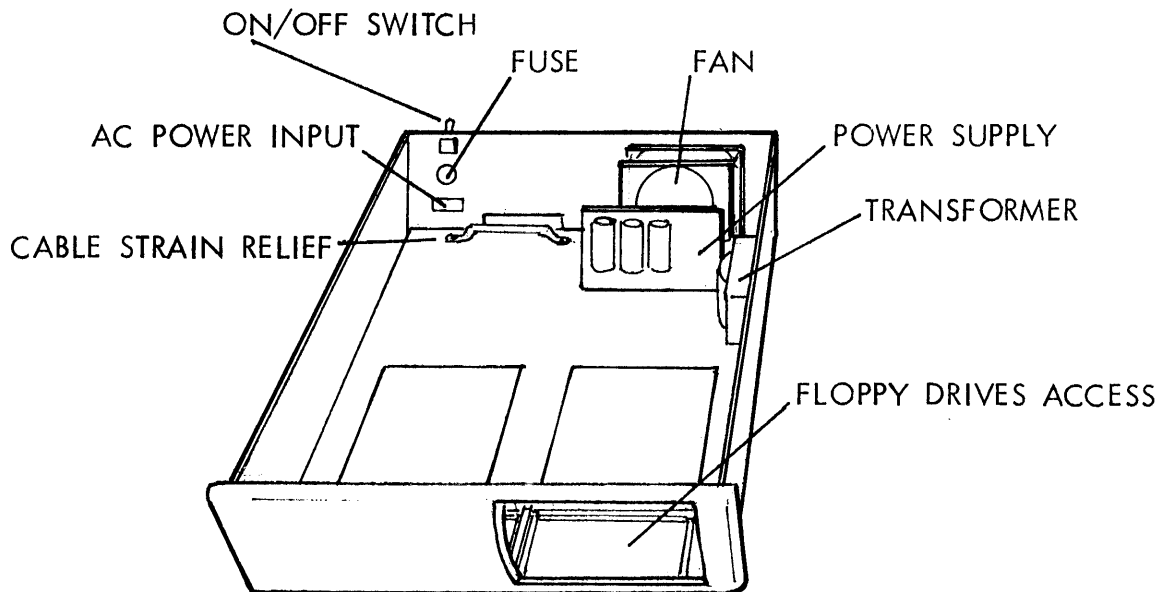

FIGURE 1: SA-H101W CHASSIS

UNPACKING AND INSPECTION

The SA-H101W is shipped in a specially designed carton for protection against abrasion and vibration. Retain the carton in case reshipment is necessary.

Unpack the 5.25" chassis and visually inspect it for damage that might have occurred during shipment. If any damage has occurred, notify Sigma Information Systems immediately.

Verify that the carton contains the following standard items:

SA-H101W 5.25" chassis with power supply, drives mounting rails, front panel, and mounting sleeve.

Hardware kit containing required hardware for rack-mounting the sleeve into a standard 19" RETMA-type rack.

The following items are optional, based on configuration specified at time of order:

Four floppy drive mounting brackets.

Bottom mounting plate for winchester drive.

Winchester formatter mounting assembly with metal bracket, insulated washers, mylar insulator sheet, and associated hardware.

34-conductor and 20-conductor formatter/winchester drive ribbon cables.

Two 50-conductor ribbon cables for winchester controller/formatter and floppy controller/drive connections.

Drive hardware mounting kit.

POWER CHECKOUT

Before installing the drives, verify correct DC power at the cable connectors. The cable connectors are illustrated, and voltages are defined, in Figure 2 below.

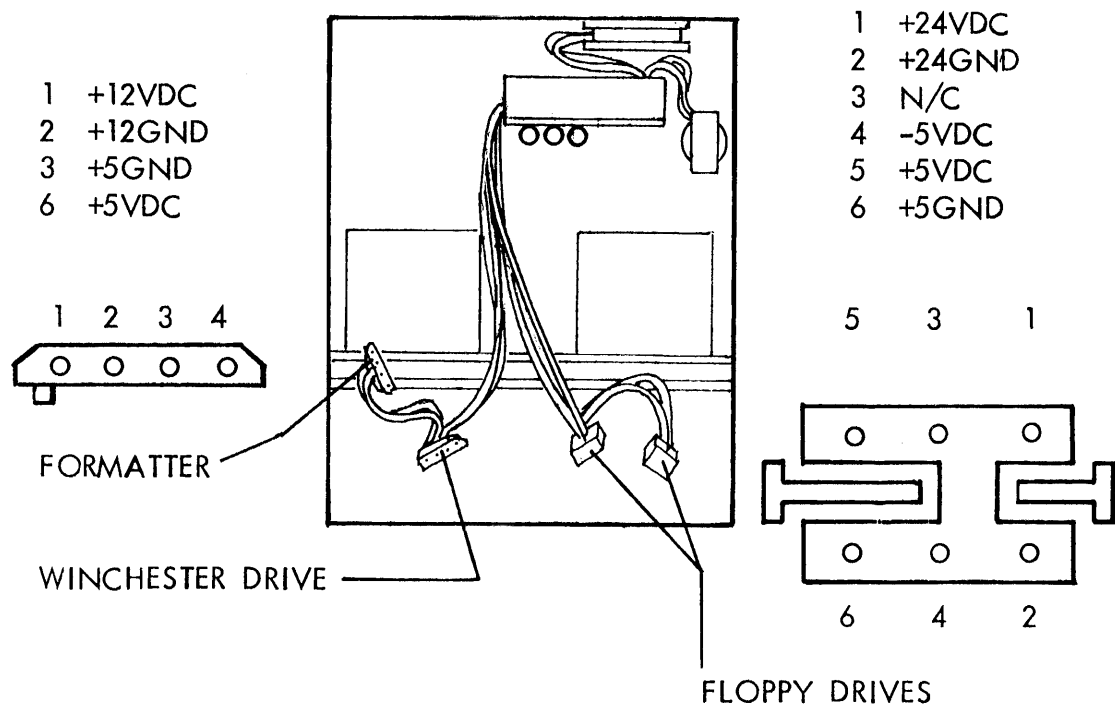

FIGURE 2: DC POWER CONNECTORS

The AC power is preset upon order. To verify correct AC configuration, or to convert between 115VAC and 230VAC, refer to Figure 3.

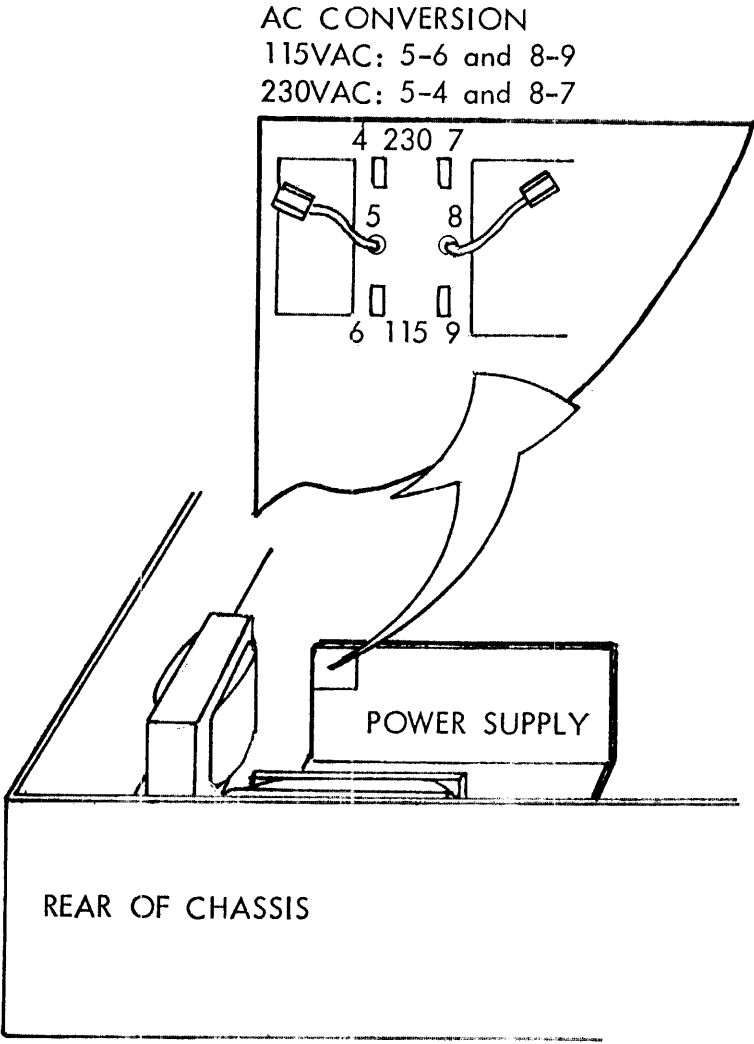

FIGURE 3: AC POWER CONFIGURATION

FLOPPY DRIVES INSTALLATION

- The following procedure is an example of floppy drives installation using the Tandem 848-2 slimline drives. Other hardware compatible drives can be installed in a similar manner. If drive manufacturer configurations differ greatly from this procedure, consult Sigma Information Systems for installation procedures.
1. Using Figure 4 as a guide, install two mounting brackets on the right side of one drives using #6-32 flathead screws.
 2. Place the drive on the spacing bar over the mounting rails (right side of chassis) and secure from the bottom mounting holes using #8-32 panhead screws.

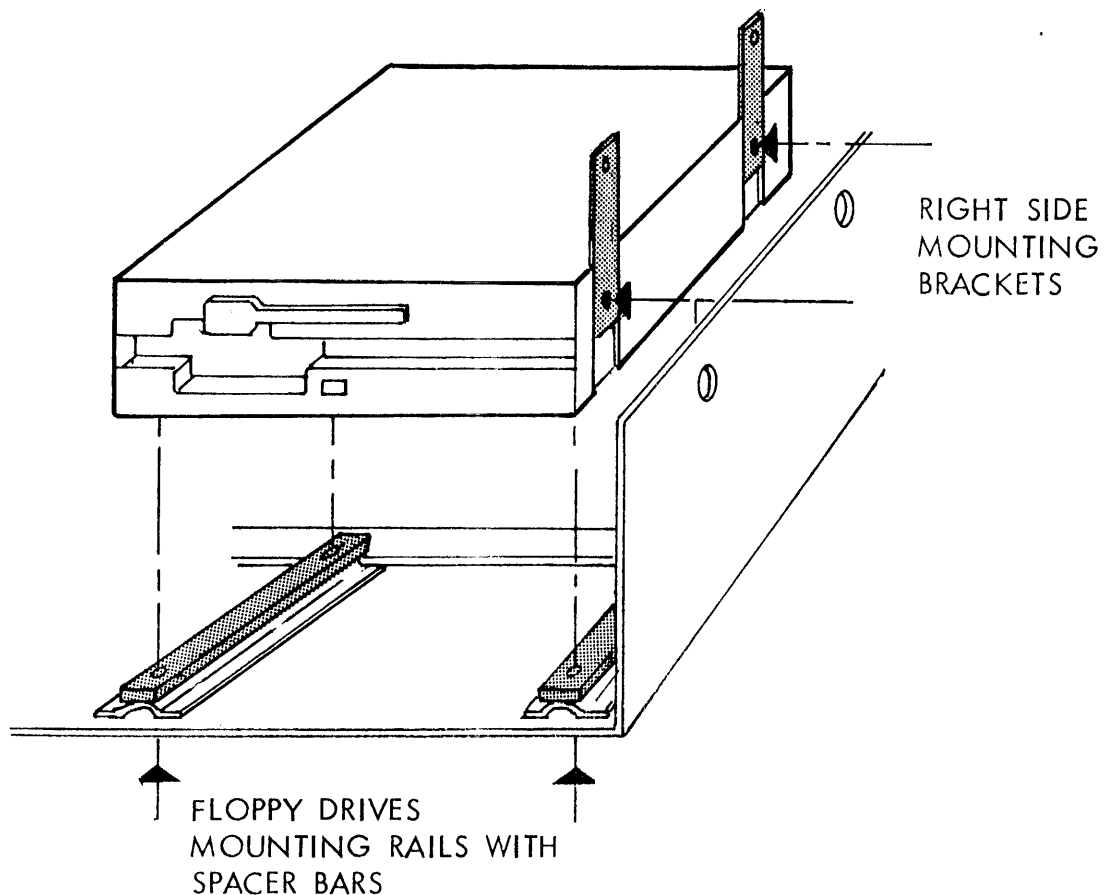

FIGURE 4: INSTALLING FIRST FLOPPY DRIVE

3. Using Figure 5 as a guide, place the second floppy drive over the installed drive. Using #6-32 flathead screws, secure the top drive to the side mounting brackets via the side access holes.
4. Install the remaining two mounting brackets on the left side of the floppy drives using #6-32 flathead screws.

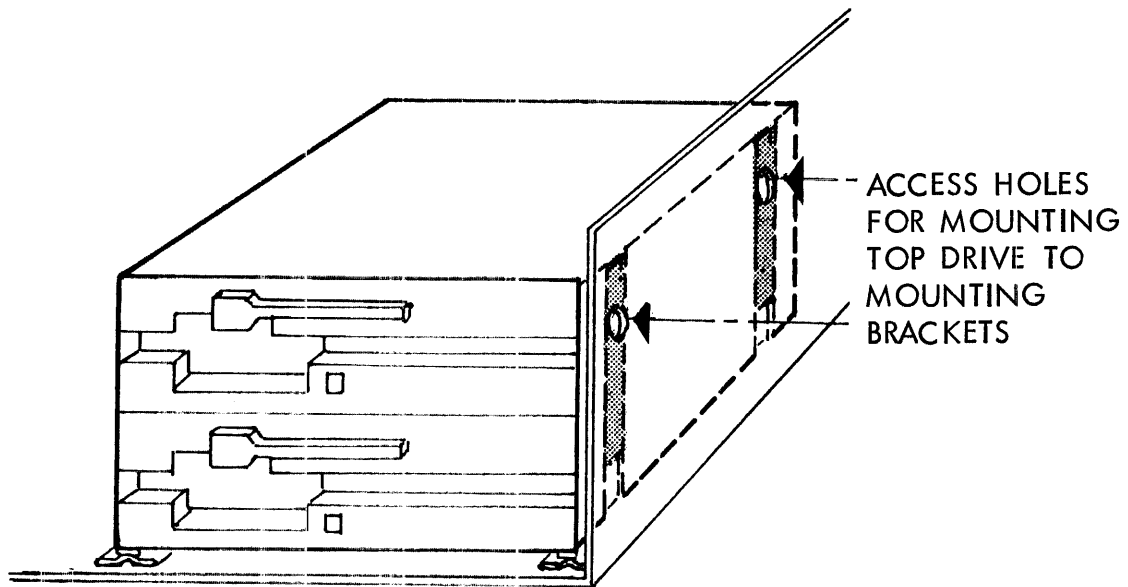

FIGURE 5: INSTALLING SECOND FLOPPY DRIVE

WINCHESTER DRIVE INSTALLATION

Using Figure 6 as a guide, perform the following procedure to install the winchester drive and formatter.

1. Install the bottom plate on the bottom of the winchester drive using #6-32 panhead screws.
2. Place the mylar sheet inside the formatter mounting bracket.

3. Insert nylon washers between the formatter module and the mylar sheet.
4. Mount the formatter module from the inside of the mounting bracket using four nylon screws.
5. Install the formatter assembly on the winchester drive and secure from the sides using #6-32 panhead screws.
6. Place the winchester drive assembly on the left mounting rails and secure from the bottom using #8-32 panehad screws.

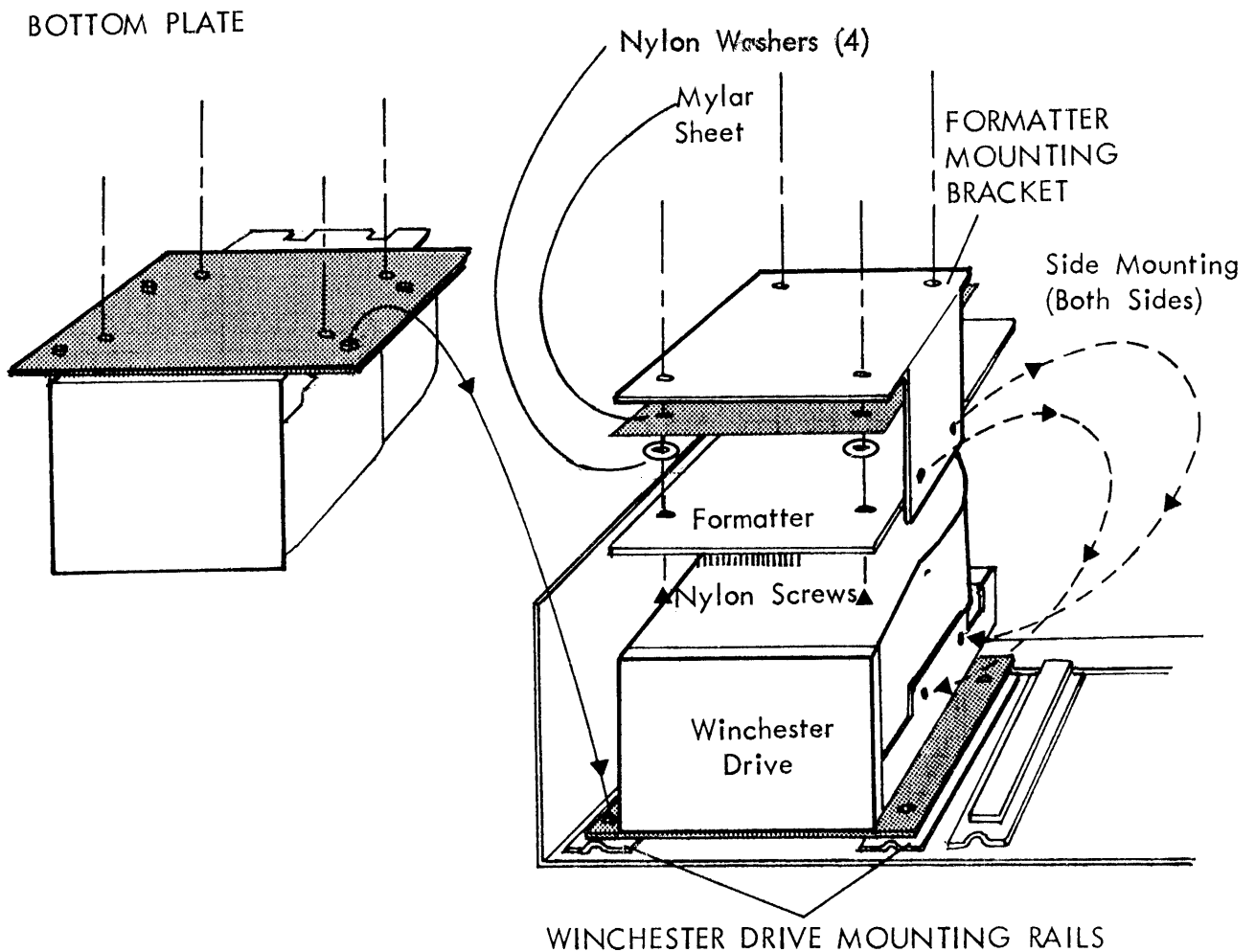

FIGURE 6: WINCHESTER DRIVE/FORMATTER INSTALLATION

CABLING

Using Figure 7 as a guide, connect the winchester drive/formatter cables.

1. Connect the 20-pin ribbon cable from formatter J2 to winchester drive.
2. Connect the 34-pin ribbon cable from formatter edge connector to winchester drive.
3. Connect the 50-conductor ribbon cable (not supplied) from front formatter connector to winchester controller.
4. Connect power cables shown in Figure 2 to associated connectors.
5. Feed the controller cable through the rear egress and secure by tightening the strain relief shown in Figure 1.

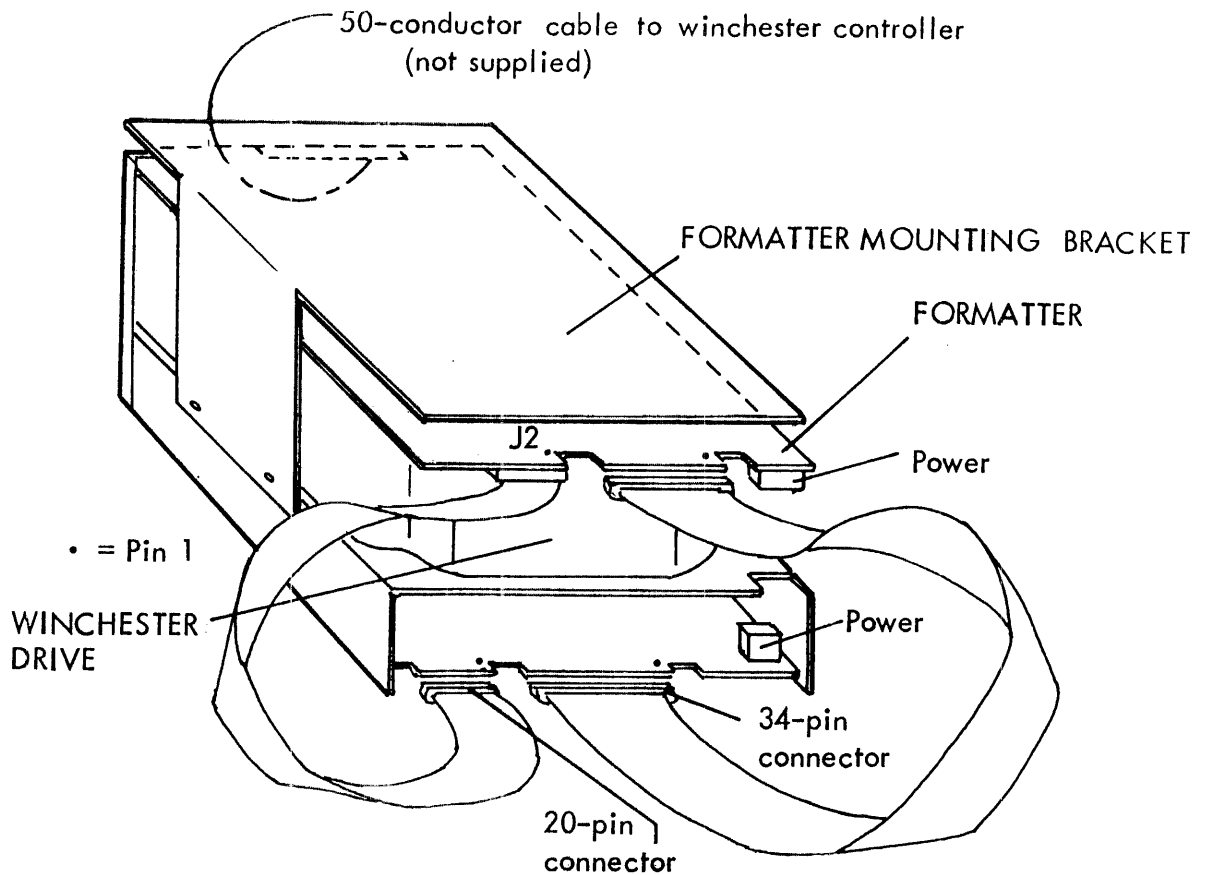

FIGURE 7: WINCHESTER DRIVE/FORMATTER CABLE CONNECTIONS

MOUNTING SLEEVE INSTALLATION

Place the mounting sleeve in the desired position in a 19" RETMA-type rack. Secure from the front and rear sides, as shown in Figure 8, with supplied hardware.

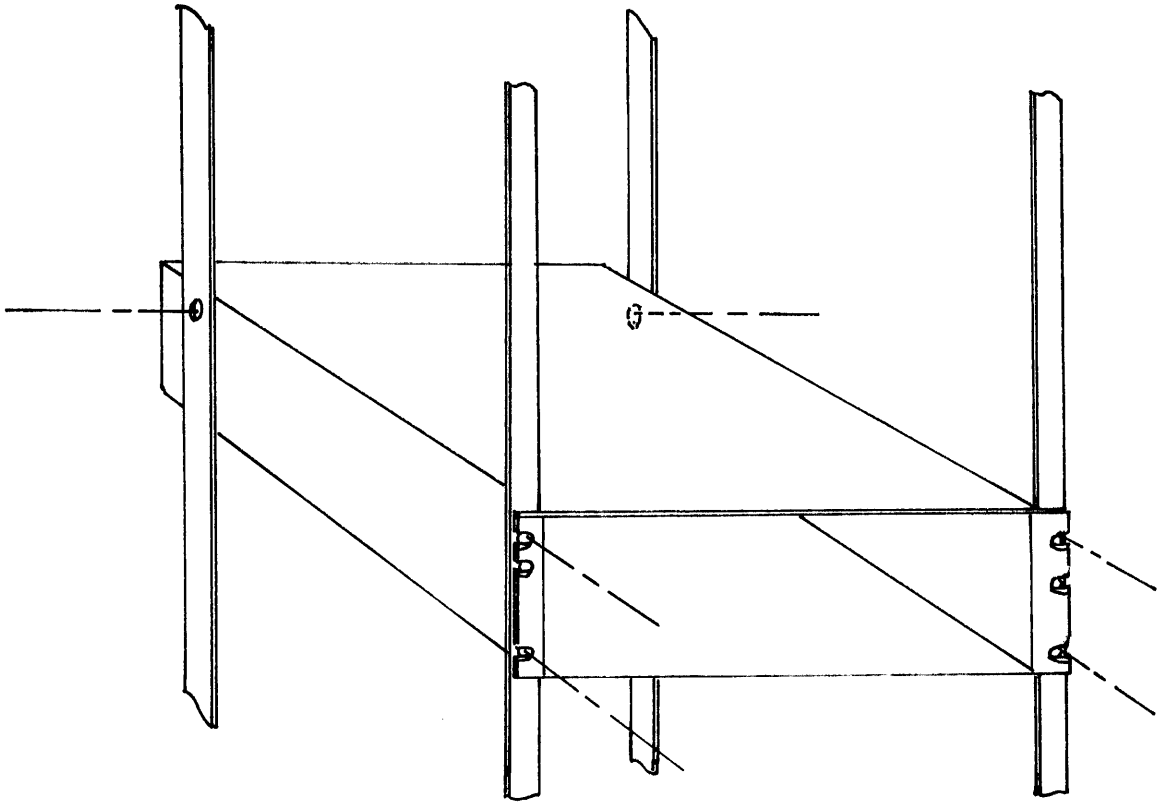

FIGURE 8: MOUNTING SLEEVE INSTALLATION

Lastly, place the 5.25" chassis inside the mounting sleeve.