

Service Manual

Flexible Disk Storage Drive

3.5 Inch

JU-314/JU-324/JU-364

CONTENTS

Page

PART 1

1. INTRODUCTION	1
2. MODELS AND MODEL NUMBERS	1
3. SPECIAL TOOLS	1
4. OUTLINE OF MAINTENANCE	2
5. DIAGNOSTIC PROCEDURES	2
5.1 Error Symptom Recognition	2
5.2 Soft Error Detection and Correction	2
5.3 Write Error	2
5.4 Read Error	3
5.5 Seek Error	3
5.6 Interchangeability Error	3
6. TROUBLE ANALYSIS	3
6.1 Trouble Analysis Procedure	3
6.2 Trouble Shooting	4
6.3 Trouble Analysis Table	5
7. PREVENTIVE MAINTENANCE	6
8. MEASUREMENT ITEMS FOR EACH MODEL	6
9. ADJUSTMENTS AND VERIFICATIONS	7
9.1 Motor Speed Adjustment and Verification (Index Period)	7
9.2 Write Protect Verification	7
9.3 Head Output Verification	7
9.4 Output Modulation Verification	8
9.5 Radial Alignment Adjustment	8~9
9.6 Azimuth Verification	10
9.7 Index Burst Verification	10
9.8 Track 00 Sensor Adjustment	11
9.9 Limiter Adjustment	11
9.10 Asymmetry Verification	11~12
10. PANASONIC ALIGNMENT DISKETTE	12

PART 2

11. REMOVALS AND INSTALLATIONS	
11.1 Removing and Remounting the Front Panel	13
11.2 Removing and Remounting the Holder Assembly	13
11.3 Removing and Remounting the head Assembly and Step Motor	13
11.4 Disassembly and Reassembly of the head Assembly and Step Motor	14
11.5 Removing and Remounting the PCB	15
11.6 Removing and Remounting the Disk Detector Assembly	16
11.7 Removal and Remounting of the Track 0 Sensor Assembly	16
12. TEST POINTS	17
13. EXPLODED VIEW	18~19
14. REPLACEMENT PARTS LIST	20~25
15. SCHEMATIC DIAGRAM OF CONTROL BOARD	26~27
16. CIRCUIT BOARD	28~29

PART. 1

1. INTRODUCTION

This service manual consists of two parts. Part 1 covers maintenance description, adjustment procedures, and trouble analysis and Part 2 covers disassembly and reassembly procedures, parts list, and PCB circuits.

Part 1 encompasses maintenance instructions for all FDD. Refer to the highlighted applicable items, and perform maintenance work on the Floppy Disk Drive (FDD).

2. MODELS AND MODEL NUMBERS

2.1 3.5-inch FDD Series

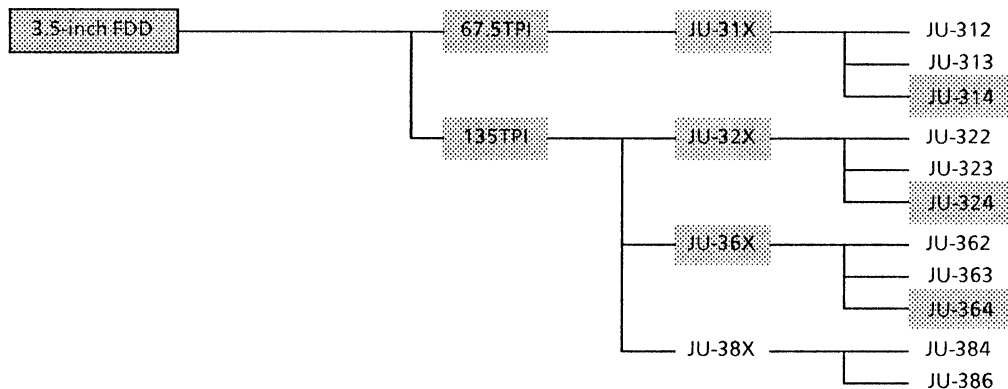

3. SPECIAL TOOLS

The following special tools are used for FDD maintenance.

TABLE 3.1

Tool	P / No.		Quantity
	JU-31X,32X,36X	JU-38X	
Exerciser	FDD-EXT-5	*←	1
Factory Alignment Diskette	817-363	817-384	1~2
Data Diskette	2DD	2DD / 2HD	1~2
CMOS/TTL Adaptor	YTFDD-CN35	*←	1
Step Motor and Head Assy Mounting Jig	YTFDD-SB35	*←	1
Oscilloscope (50MHz)			1
Probe (10:1)			1
Frequency Counter			1

Note: *← : Stand for the same as left.

4. OUTLINE OF MAINTENANCE

- The following tools are required for maintenance of a Floppy Disk Drive.

4.1 Alignment Diskette

Alignment diskette is used for head actuator alignment and index sensor adjustment. Use the right diskette as shown in Table 3.1.

4.2 Exerciser

The exerciser enables you to make all adjustments and inspections necessary for an FDD. Its functions include the following:

- (1) Seek increment or alternate tracks
- (2) Read (but no data compare)
- (3) Write 1F or 2F (All 0's or 1's)
- (4) Recalibration to track 00

The exerciser has switches and indicators to execute a specified function.

5. DIAGNOSTIC PROCEDURES

5.1 Error Symptom Recognition

Errors that occur because of the wrong operating procedure, wrong programming, or use of a defective diskette, or soft errors due to external causes, such as contaminated air and random electrical noise, are often attributed to a drive failure.

Unless a visual inspection of the drive reveals an evident assembly fault or a defect, always confirm errors with another good diskette, and another known good drive.

5.2 Soft Error Detection and Correction

Soft errors are normally caused by the following:

- (1) Contamination between read/write heads and diskette. This kind of contamination can be easily eliminated by the liner in the diskette. Contaminated heads can be cleaned by a general purpose non-abrasive head cleaning diskette. Please follow the suitable procedure provided with the cleaning diskette.
- (2) Random electrical noise, normally a few microseconds or less.
- (3) Small defects in written data and/or track not detected during write operation may cause soft errors during read.
- (4) Faulty grounding of the drive or host system can also cause a soft error.
- (5) Wrong motor speed is another cause of soft errors.

Take the following steps on the controller side to recover from the soft errors mentioned above.

- (1) Read the track again ten times or until the data is recovered.
- (2) If Step (1) above fails to recover the data, access the adjacent track. Then return the head to the original track.
- (3) Repeat Step (1).
- (4) Any error that cannot be corrected by the above procedure is irrecoverable.

5.3 Write Error

If an error occurs during write operation, it is usually detected during the next revolution by performing a read operation called write check. To correct an error, write again and repeat a write check operation. If the result is unsatisfactory after ten or more write operations, perform a

read operation on another track to determine whether it is the diskette or the drive that is wrong. If an error persists, replace the diskette and repeat the above procedure. If the error still persists, consider the drive defective. If the error is corrected, dispose of the diskette as defective.

5.4 Read Error

Most read errors are soft errors. Data can be recovered by following the recovery procedure mentioned in 5.2.

5.5 Seek Error

(1) Stepper motor or stepper motor drive circuit is faulty.

(2) Faulty carriage

There are two ways of seek error recovery. One is to recalibrate to track 00, and seek back to the original track. The other is to read the ID field, check the track number on which the head is located, and move the head away from it. And read it again.

5.6 Interchangeability Error

Data which is written by one drive may not be read by another. This error is called a Interchangeability error, which can be caused mostly by the following reason, which should be checked as follows.

(1) Head misalignment: Refer to Adjustments and Confirmation Item 9.5

(2) Head output too low: Refer to Adjustments and Confirmation Item 9.3

(3) Motor speed difference: Refer to Adjustments and Confirmation Item 9.1

(4) Format difference

6. TROUBLE ANALYSIS

6.1 Trouble Analysis Procedure

FDD trouble may occur in any of the following nine forms.

(1) Index detection failure

(2) Not ready

(3) Track 0 undetectable

(4) No seek

(5) No write

(6) No read

(7) Read error

(8) IN USE LED won't light.

(9) Write protect undetectable

Check with the troubleshooting flowchart in 6.2

CAUTION:

Be sure to switch power off before removing an FDD or PCB from the operating system.

6.2 Trouble Shooting Flow Chart

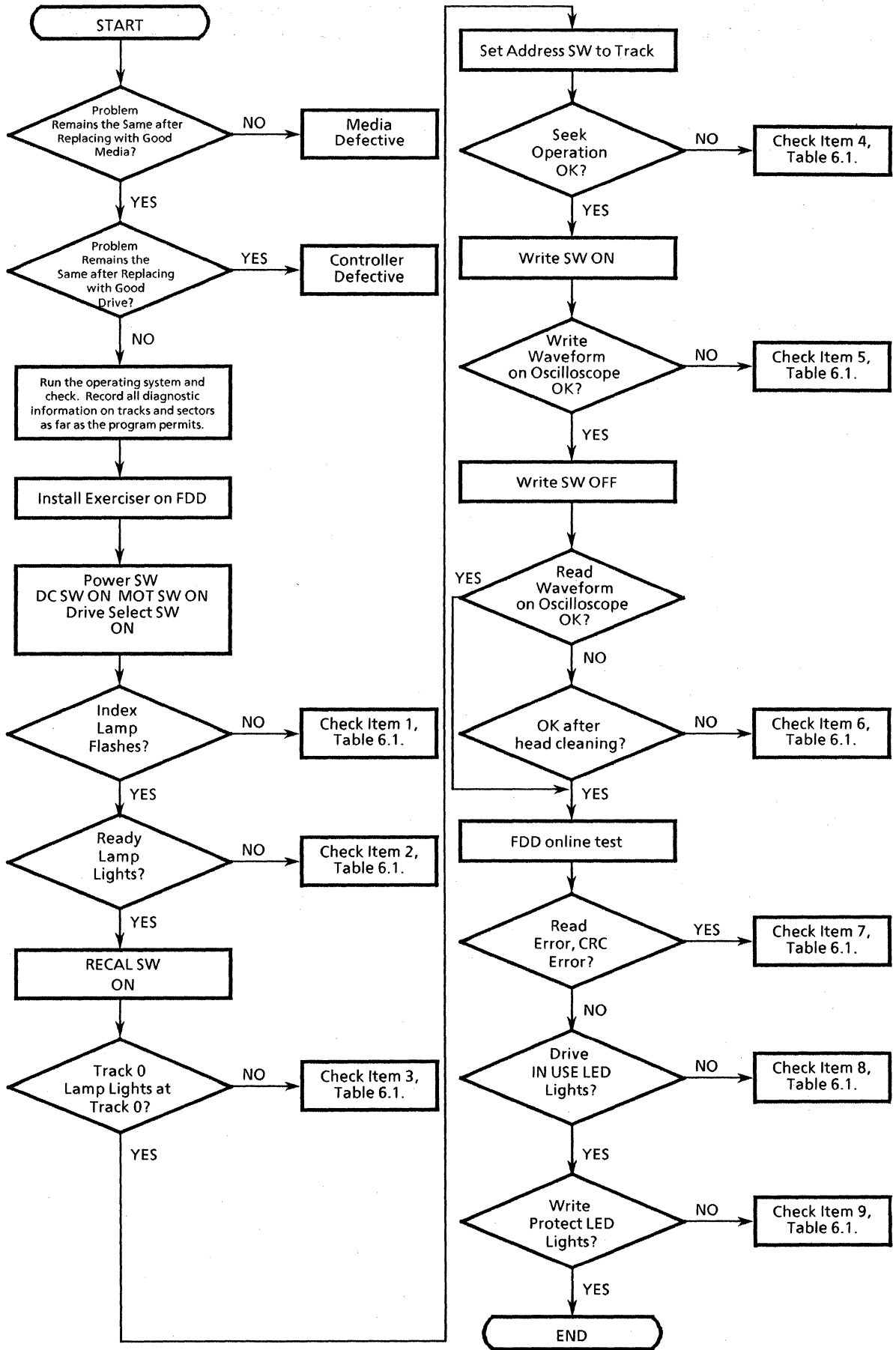

6.3 Trouble Analysis Table

Table 6.1

Item	Trouble	No	Cause	JU-3X3, 3X4, 38X	JU-3X2
1	Index detection failure	1	DD motor control PCB	Replace DD motor, Base assembly	Replace DD motor assembly
		2	DD motor faulty		
		3	Index LED faulty	Replace DD motor, Base assembly	Replace
		4	Index detector faulty		
		5	PCB motor ON circuit	Repair	* ←
		6	PCB index detection circuit	Repair	* ←
2	Not ready	1	See Item 1.		
		2	PCB ready circuit	Repair	* ←
3	Track 0 detection failure	1	Track 00 assembly	Replace	* ←
		2	PCB track 0 detection failure	Repair	* ←
4	No seek	1	Stepper motor	Replace	* ←
		2	Guide shaft contamination or damaged	Replace	* ←
		3	PCB stepper driver circuit	Repair	* ←
5	No WRITE	1	See Item 1.		
		2	Head disconnected	Replace	* ←
		3	Head shorted	Replace	* ←
		4	PCB write circuit	Repair	* ←
6	No READ	1	See Item 1.		
		2	See Item 5.		
		3	PCB read circuit	Repair	* ←
7	READ ERROR	1	See Item 1.		
		2	See Item 6.		
		3	Alignment	Adj.	* ←
		4	Azimuth	Unadjustable	* ←
		5	Burst	Unadjustable	Unadjustable
		6	Asymmetry	Adj.	
		7	Limitter	Adj.	Adj.
		8	Flag 0	Adj.	* ←
		9	Index period	Replace DD motor, Base assembly	Replace
		10	PCB read circuit	Repair	* ←
8	IN USE LED won't light.	1	LED part	Replace	* ←
		2	PCB IN USE circuit	Repair	* ←
9	Write protect failure	1	Write protect part	Replace DD motor, Base assembly	Replace
		2	Write protect circuit	Repair	* ←

Note: * ←: Stand for the same as left.

7. PREVENTIVE MAINTENANCE

No preventive maintenance is necessary for any type of FDDs under normal conditions of use. However if it is determined that adjustments are necessary, the following must be done.

- **Adjustments (Refer to table 8.1)**

- (1) Specify an applicable model from Table 8.1, and make a read/write head radial adjustment at a specified track.
(Sides 0,1)
- (2) Make an index timing adjustment at a specified track. (Sides 0,1)
- (3) Make an azimuth measurement at a specified track. (Sides 0,1)

CAUTION

Do not write when using alignment diskette. Check that write protect sensor is properly operating with a data diskette.

Note : Section 9 describes the adjustment procedures in detail.

8. MEASUREMENT ITEMS FOR EACH MODEL

Table 8.1

Item	Parameter	JU-31X		JU-32X,36X		JU-384	
		TRK	Value	TRK	Value	TRK	Value
1	Index period	20	200 ± 3 ms	40	200 ± 3 ms	40	166.6 ms ± 1 %
2	Output level	39	160 mV or more	79	180 mV or more	79	160 mV more than
3	Radial Alignment	20	75 %	40	50 %	40	50 %, ± 25 μm
4	Azimuth	20	± 18'	40	± 18'	40	± 18'
5	Index burst	20	3 ± 1.5 ms	40	3 ± 1.5 ms	40	2.5 ± 0.85 ms
6	Flag 0	From track 1 to track 2 and back	1:1	From track 1 to track 2 and back	1:1	From track 1 to track 2 and back	1:1
7	Limiters	- 1	Recalibrate and return to 0	- 1	Recalibrate and return to 0	- 1	Recalibrate and return to 0
8	Asymmetry	39	< 600 ns	79	< 600 ns	79	< 350 ns

* Value of Item 3, 4, 5 : only DAD (Dynamic Alignment Diskette) typ.

9. ADJUSTMENTS AND VERIFICATIONS

9.1 Motor Speed Adjustment and Confirmation (Index Period)

- (1) Insert a diskette, run the motor, and clamp. Refer to the index period column of Table 8.1 for the applicable model.
- (2) Step to the specified track.
- (3) Connect a frequency counter to the INDEX signal.
IX (INDEX)
- (4) Check that the frequency counter readings meet the specifications in the table.

9.2 Write Protect Verification

- (1) Check that the exerciser's write protect lamp goes on and off as a media is inserted and removed as specified in the table below.

Media with write protect hole open : ON
Media with write protect hole closed : OFF

9.3 Head Output Verification

Use a new diskette if possible to identify head failure for this check.

- (1) Insert a good diskette.
- (2) Run the motor.
- (3) Step to the track specified in the output level column of Table 8.1.
- (4) Connect the oscilloscope probe as specified below.

CH1 : T1
CH2 : T2
EXT : IX (Index)

Invert channel 2 and select the Add mode.

Set vertical deflection to 10 mV/division and horizontal deflection to 20 ms/division.

- (5) Write 2F (all ones) on the entire circumference.
(In case of a double-sided FDD, repeat it on sides 0 and 1 using SIDE SELECT.)
- (6) Check that the average output level meets the specifications of Table 8.1. If it does not meet the specifications, refer to Item 7 of the Trouble Analysis Table.

9.4 Output Modulation Verification

Modulation: M is calculated by the following formula.

$$M(\%) = \frac{V_{\max} - V_{\min}}{V_{\max} + V_{\min}} \times 100$$

using the value obtained in 9.3, and check that the calculated value is 20% or less.

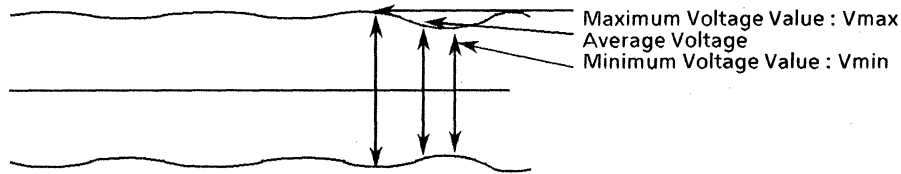

Fig. 9.1 Modulation

9.5 Radial Alignment Adjustment

Introduction

This adjustment is normally not necessary.

If the mounting screws for the stepper motor loosen, or if parts become defective, or if a compatibility error occurs, check and readjust according to the following procedure.

Steps (4) to (9) below should be performed regardless of the type, CE or DAD alignment diskette used. Use an alignment diskette suitable to the type of FDD to be adjusted according to table 3.1

- (1) Insert an alignment diskette.

CAUTION:

Be sure to leave the alignment diskette under room conditions for 20 minutes before adjustment.

- (2) Step to the track specified in the Radial alignment column of Table 8.1.
- (3) Leave the oscilloscope in the same condition as mentioned in section 9.3.

● Cats Eye System

- (4) Check the output waveforms for sides 0 and 1. They should appear as in Fig. 9.2.
- (5) The two waveforms should appear in the amplitude ratio in the R/A column of Table 8.1 or better.
- (6) If the specified ratio is not satisfied, loosen the two mounting screws for the stepper motor.
- (7) Move the stepper motor along the base by hand until the two waveforms assume approximately the same amplitude, and retighten the mounting screws. (See Fig. 9.2.)
- (8) Step the head outward (track 0) and inward (track 40 or 79), and confirm that the adjustment has been completed.
- (9) After the radial adjustment, be sure to confirm track 00 sensor adjustment 9.8 and carriage limiter 9.9.

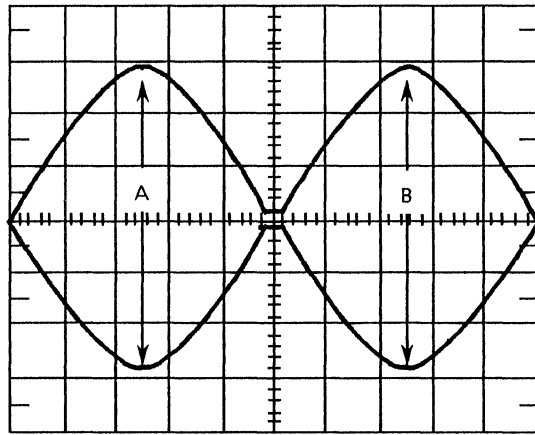

$$A > B : \frac{B}{A} \times 100$$

$$B > A : \frac{A}{B} \times 100$$

Fig. 9.2 Radial Alignment Waveforms (CATS EYE)

Note: Alignments on sides 0 and 1 are adjusted at the factory. If they are misaligned, adjust them to meet the specifications of Table 8.1.

- **DAD (Dynamic Alignment Diskette)**

- (4) Watch the output waveforms for sides 0 and 1. They should appear as shown in Fig. 9.3.
- (5) Measure the timing levels A1 to A4 and B1 to B4 in Fig. 9.3, and calculate the lobe ratio from the following formulas.

$$\Sigma A > \Sigma B : \frac{\Sigma B}{\Sigma A} \times 100\% \qquad \Sigma A < \Sigma B : \frac{\Sigma A}{\Sigma B} \times 100\%$$

- (6) The lobe ratio calculated by the above formulas should meet the specifications on item 3 of Table 8.1.
- (7) If the above requirement is not met, loosen the two mounting screws for the stepper motor, adjust.
- (8) Seek from track 0 to track 40 and from track 79 to track 40, and confirm that the adjustment has been completed.
- (9) After the radial adjustment, be sure to confirm track 00 sensor adjustment 9.8 and head carriage limiter 9.9.

Note: An alignment instrument for 3.5-inch FDDs permits accurate and easy adjustment because the lobe ratio is displayed on the instrument.

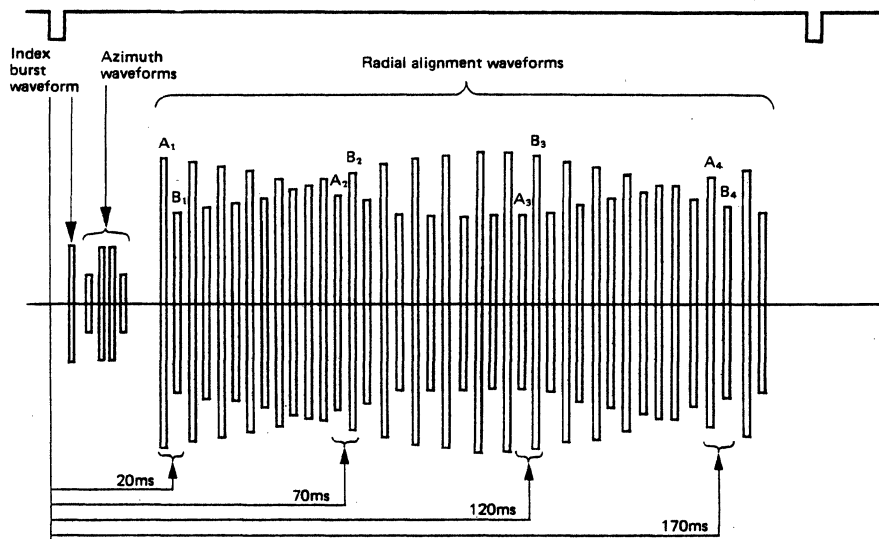

Fig. 9.3 Alignment Waveform (DAD)

9.6 Azimuth Verification

- (1) Insert an alignment diskette. Seek to the track specified in the azimuth column of Table 8.1.
- (2) Set the oscilloscope in the same conditions as in 8.3, and set horizontal deflection to 0.5 ms/division.
- (3) Measure as shown below.
- (4) Confirm that the measured value meets the specifications in the azimuth column of Table 8.1.

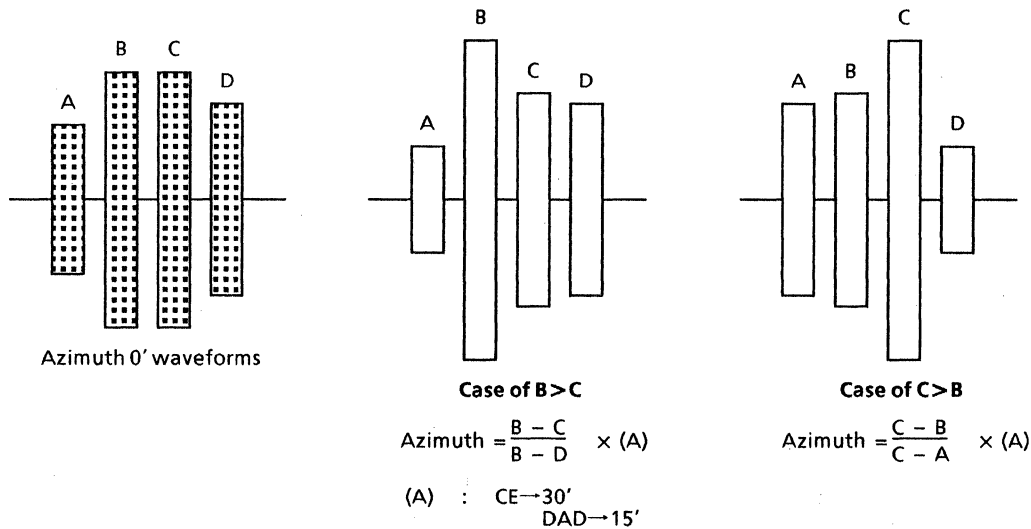

Fig. 9.4 Azimuth Waveforms

9.7 Index Burst Verification

- (1) Insert an alignment diskette. Seek to the track specified in the I/B column of Table 8.1.
- (2) Set the oscilloscope time base as follows:
1 ms/division
- (3) Check that the time from oscilloscope start to the first data pulse meets the I/B specifications of Table 8.1. (DAD system)
- (4) If the specifications are not met, No adjustment necessary for 3.5-inch models.

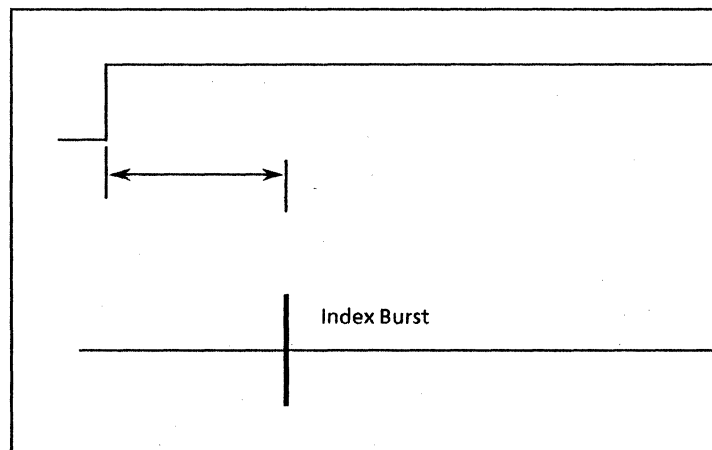

Fig. 9.5 Index Timing

9.8 Track 00 Sensor Adjustment

- (1) Set the oscilloscope as follows.
Set horizontal deflection to 1ms/division.

CH1 : ZP
EXT : SP

- (1) Step between specified tracks at in the FLAG 0 item of Table 8.1 (Turn the seek delay switch on the exerciser to adjust 12 ms seek.)
- (3) Loosen the track 0 sensor screw and adjust until the waveform on the oscilloscope appears as shown in Fig. 9.9.

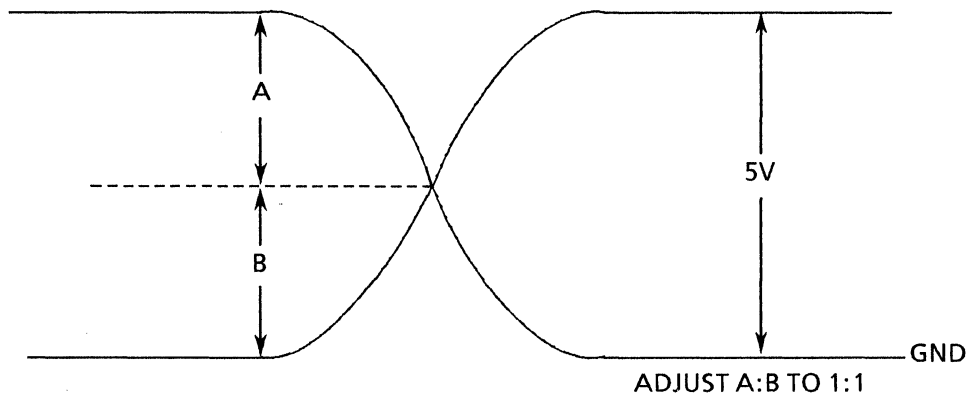

Fig. 9.86 Track 0 Waveform

9.9 Limiter Adjustment

- (1) Seek to track 0.
- (2) Write 2F data on track 0, and measure read level.
- (3) Loosen the limiter mounting screw to free the limiter.
- (4) Move the limiter until it just touches the head carriage on - 1 track, and retighten the limiter mounting screw securely.
- (5) Check that, when the RECAL switch on the exerciser is pushed ON, the head returns to track 0 and that the 2F output level is the same as that measured in Step (2).

9.10 Asymmetry Verification

- (1) Insert a data diskette.
- (2) Step to the track specified in the symmetry item of Table 8.1.
- (3) Set the oscilloscope as follows:

CH1 : RD
CH2 : T1

- (4) Write 1F.
- (5) A read wave form is displayed on the oscilloscope as shown in Fig. 9.7.
- (6) Confirm if it satisfies the value as shown in Table 8.1.

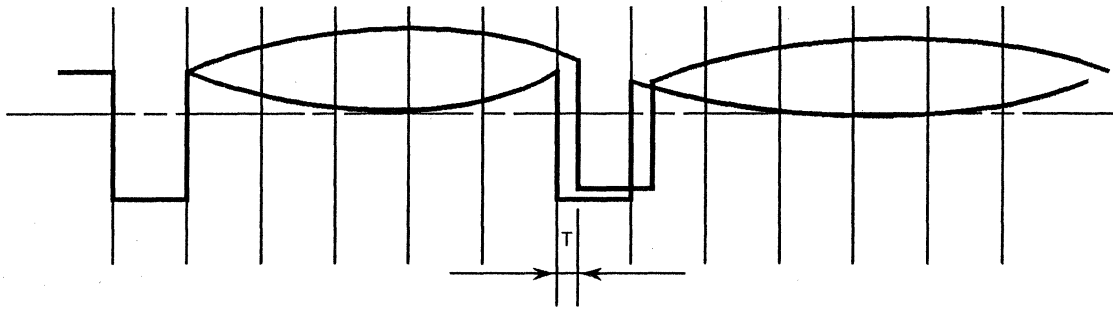

Fig. 9.7 Asymmetry Waveform

10. PANASONIC ALIGNMENT DISKETTE

3.5 inch Alignment Diskette

Table 10.1

TPI	P/N		Index Burst	Azimuth	Radial Alignment	MODEL
67.5	817-363		20TRK	20TRK	20TRK	JU-31X
135	817-363		40TRK	40TRK	40TRK	JU-32X JU-36X
135	817-384		40TRK	40TRK	40TRK	JU-38X

PART. 2

11. DISASSEMBLY AND REASSEMBLY

11.1 Removing and Remounting the Front Panel

- (1) Remove the two cover fastening screws and remove the cover.
- (2) Remove the two front-panel fastening screws and remove the front panel.
- (3) Remount them in the reverse order of the above.

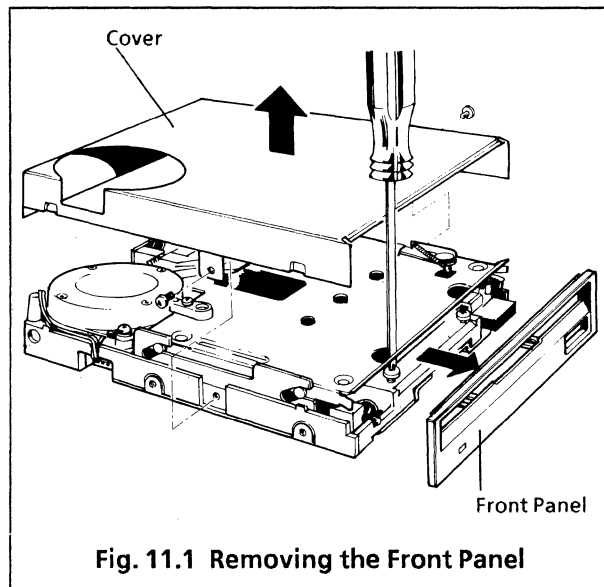

Fig. 11.1 Removing the Front Panel

11.2 Removing and Remounting the Holder Assembly

- (1) Remove the front panel following the procedure in paragraph 11.1.
- (2) Remove each lever fastening screw and remove the two levers.
- (3) Lift the holder assembly by hand so that the edge of the holder assembly does not touch the lever assembly as shown in figure 11-2 and remove it by sliding it toward the front side. In this case, lift the side 1 of the head assembly by the thumb, otherwise it strikes side 0 due to the head retaining spring on the side 1 when it drops from the holder.
- (4) Remount it in the reverse order of the above.
- (5) Check the operation of the holder assembly after it has been remounted.
- (6) Operation check of the holder assembly
 - a) When mounting the two levers, temporarily fasten the fastening screws.
 - b) Slide in and out the media several times and confirm that the movement is smooth.

- c) After properly tightening the two screws, reconfirm that the movement is smooth.

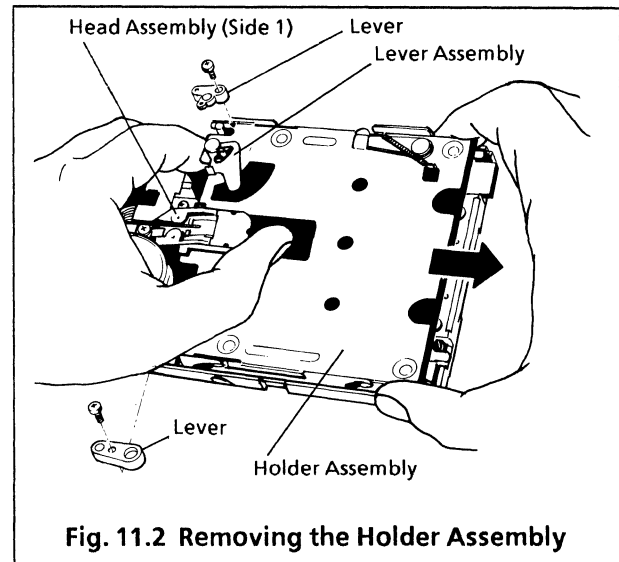

Fig. 11.2 Removing the Holder Assembly

11.3 Removing and Remounting the head Assembly and Step Motor

- (1) Remove the holder assembly following the procedure in paragraph 11.2.
- (2) Push up and remove the FPC clamp using such as tweezers.
- (3) Pull up the FPC contact part inserted into the head connector J3 by picking it up with such as flat pens so as not to damage it.
- (4) Remove the step motor cable connector from the J4 connector on the PCB.

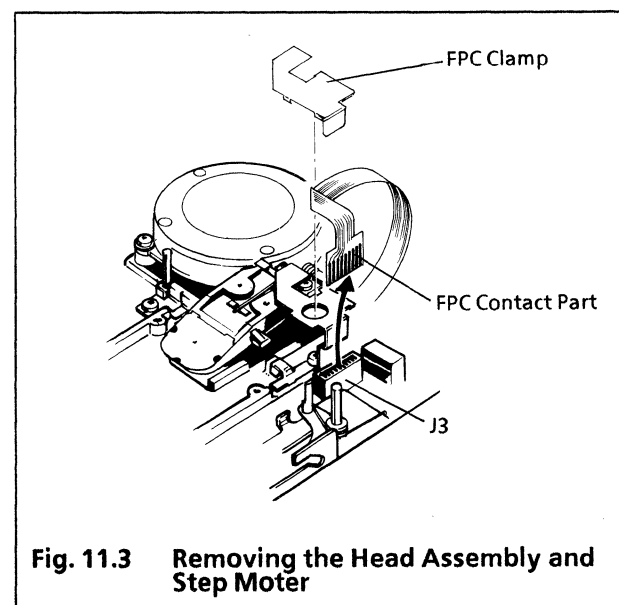

Fig. 11.3 Removing the Head Assembly and Step Motor

- (5) Remove the set screw on the right-side clamp and remove the right-side clamp.

- (6) Remove the set screw on the left-side clamp and remove the left-side clamp.
- (7) Remove the set screw on the clamp end and remove the clamp end.
- (8) Draw out the long and short shafts.

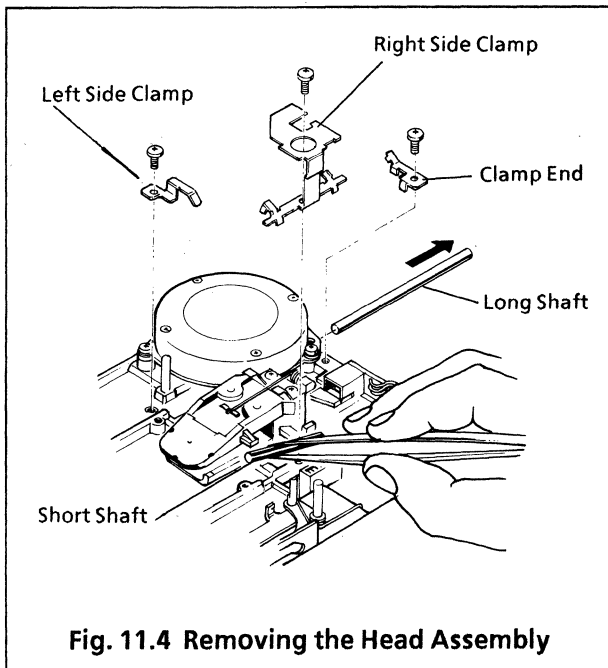

Fig. 11.4 Removing the Head Assembly

- (9) Remove the two fastenings on the step motor and remove the step motor by holding it by hand together with the head assembly.

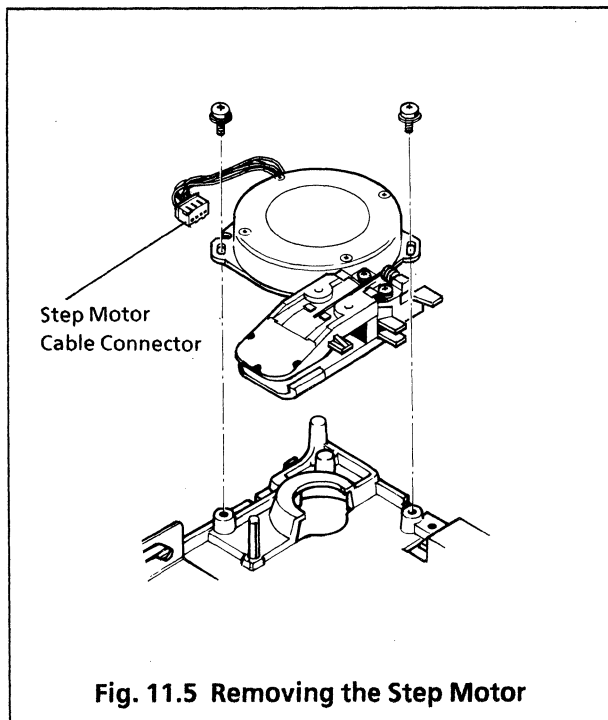

Fig. 11.5 Removing the Step Motor

- (10) Remount them following the reverse procedure of the above steps (1) to (9).

When remounting the right-side clamp in step (5), remount it while pushing it in the arrow direction shown in figure 11-6. When remounting the right-side left-side clamps, replace them with new ones.

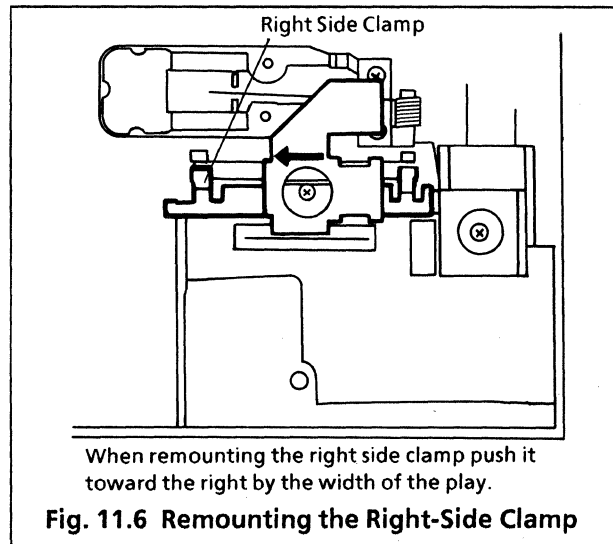

Fig. 11.6 Remounting the Right-Side Clamp

- (11) After mounting the above, adjust the head alignment according to paragraph 9.5, adjust the track 00 sensor according to paragraph 9.8, and adjust the limiter according to paragraph 9.10.

11.4 Disassembly and Reassembly of the head Assembly and Step Motor

Disassembly

- (1) Mount the head assembly and step motor on a fitting jig as shown in figure 11-7 and remove the steel-belt fastening screw on the step-motor capstan and the same on the carriage section.

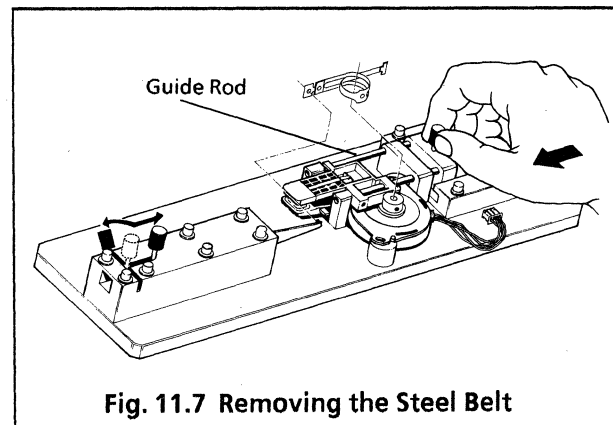
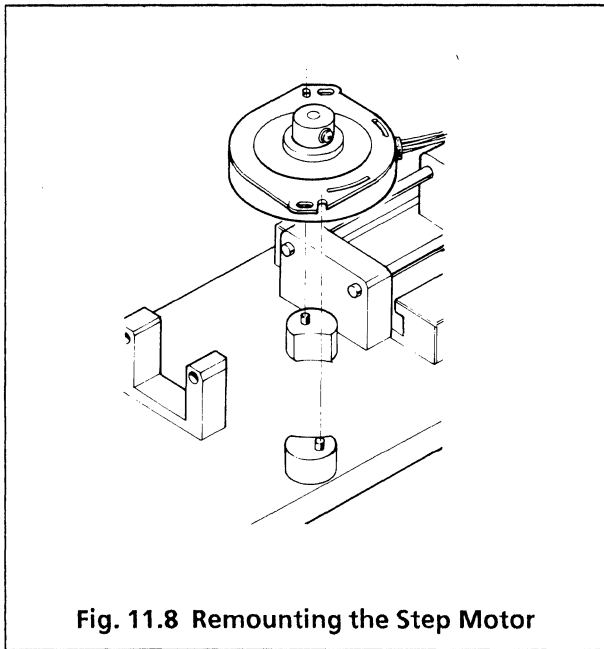

Fig. 11.7 Removing the Steel Belt

Reassembly

- (1) Mount the step motor and head on the jig as shown in figure 11-8 and 11-9.
- (2) Wind a new steel belt in the shape of alpha as shown in figure 11-9.



- (3) Set the hook A of the steel belt to the carriage tab.
- (4) Set the ring of the steel belt wound in the shape of alpha to the capstan.
- (5) Insert the guide rod into the head carriage.
- (6) Pull out the hook B of the steel belt with tweezers and set it to the tab on the jig. Set the tension handle in the arrow direction.

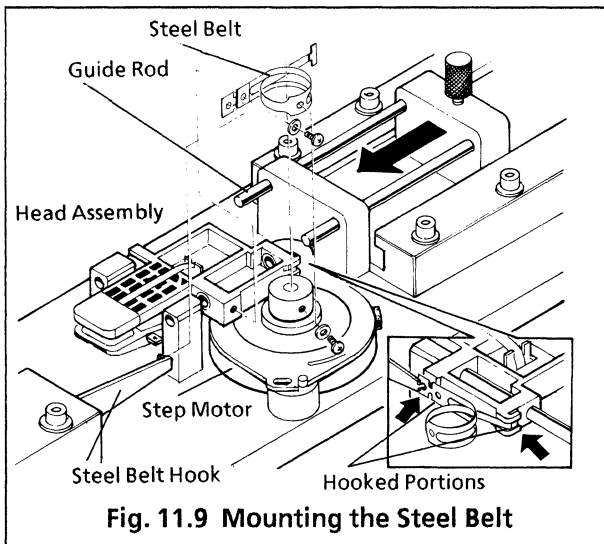

- (7) Retighten the capstan fastening screws and carriage section fastening screws. In this case check if the steel belt is bent or distorted and also alignment.
- (8) Return the tension handle to the original position and unhook the steel belt.
- (9) Check the smooth operation of the carriage by moving it back and forth.
- (10) Pull out the guide rod.

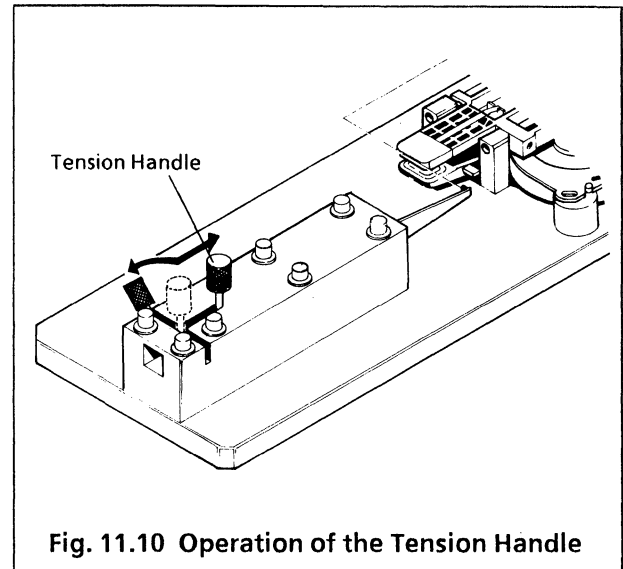

- (11) Cut the hook B with a nipper.

11.5 Removing and Remounting the PCB

- (1) Remove each two screws on the right-side and left-side brackets and remove the right-side and left-side brackets.
- (2) Remove connectors J3, J4, and J5, J6 from the PCB.
- (3) Remove the two fastening screws on the PCB and remove the PCB.

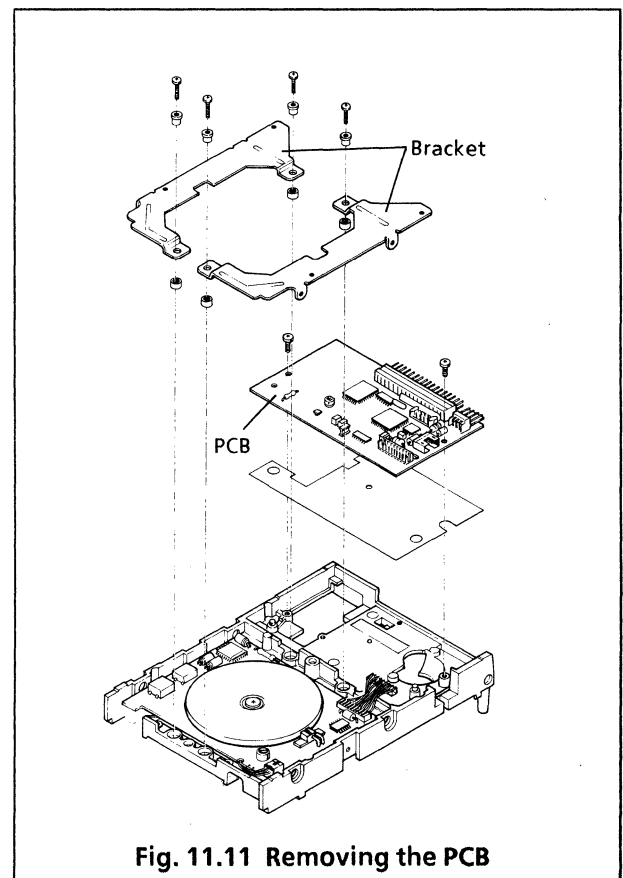

- (4) Remount it following the reverse order of steps (1) to (3).
Treat the J5 cable as shown in figure 11-12 when remounting the PCB. Set the PCB beneath the base as shown in the figure.

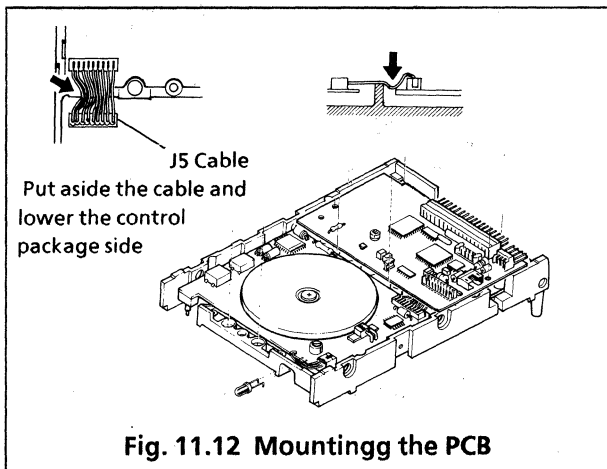

Fig. 11.12 Mounting the PCB

11.6 Removing and Remounting the Disk Detector Assembly

- (1) Remove the holder assembly following the procedure in paragraph 2.
- (2) Remove the right-side and left-side brackets.
- (3) Remove the disk detector cable connector from the J3 terminal.
- (4) Remove the disk detector fastening screws and remove disk detector.
- (5) Remount it following the reverse order of steps (1) to (4).

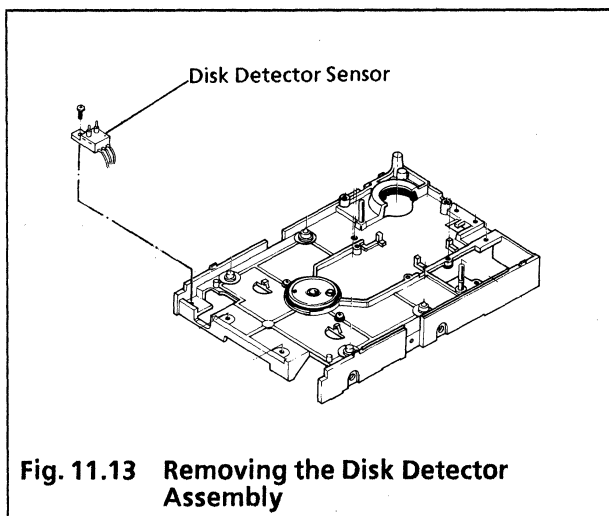

Fig. 11.13 Removing the Disk Detector Assembly

11.7 Removal and Remounting of the Track 0 Sensor Assembly

- (1) Remove the cover

- (2) Remove the cable connector from the J6 terminal.
- (3) Remove the track sensor assembly fastening screws and remove the track sensor assembly.
- (4) Remount it following the reverse order of steps (1) to (3).
- (5) Adjust the track 00 sensor according to the procedure in paragraph 9.8 after remounting it.

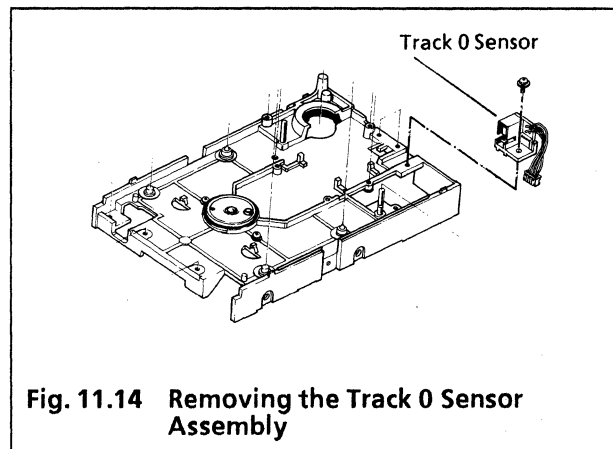
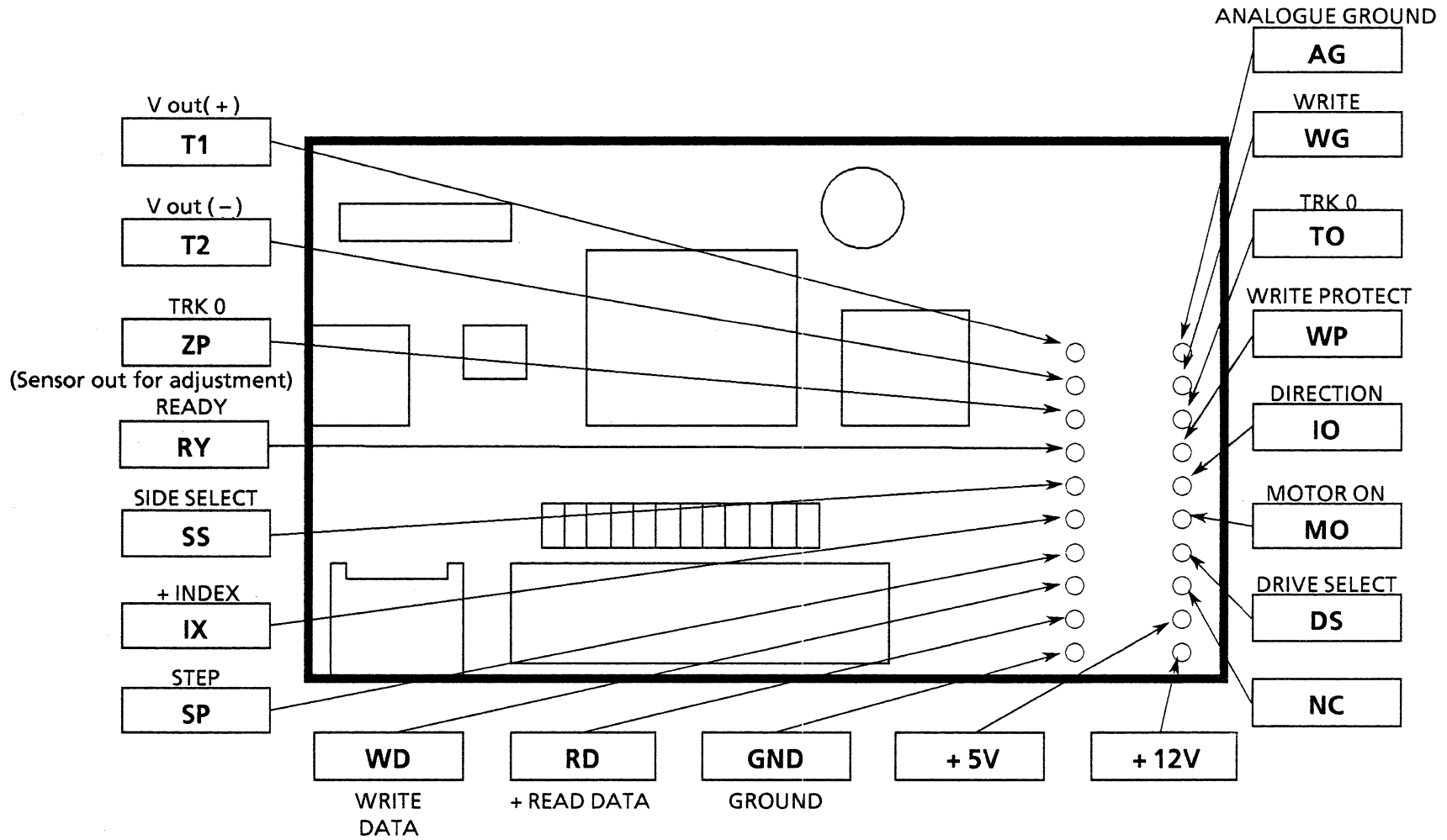
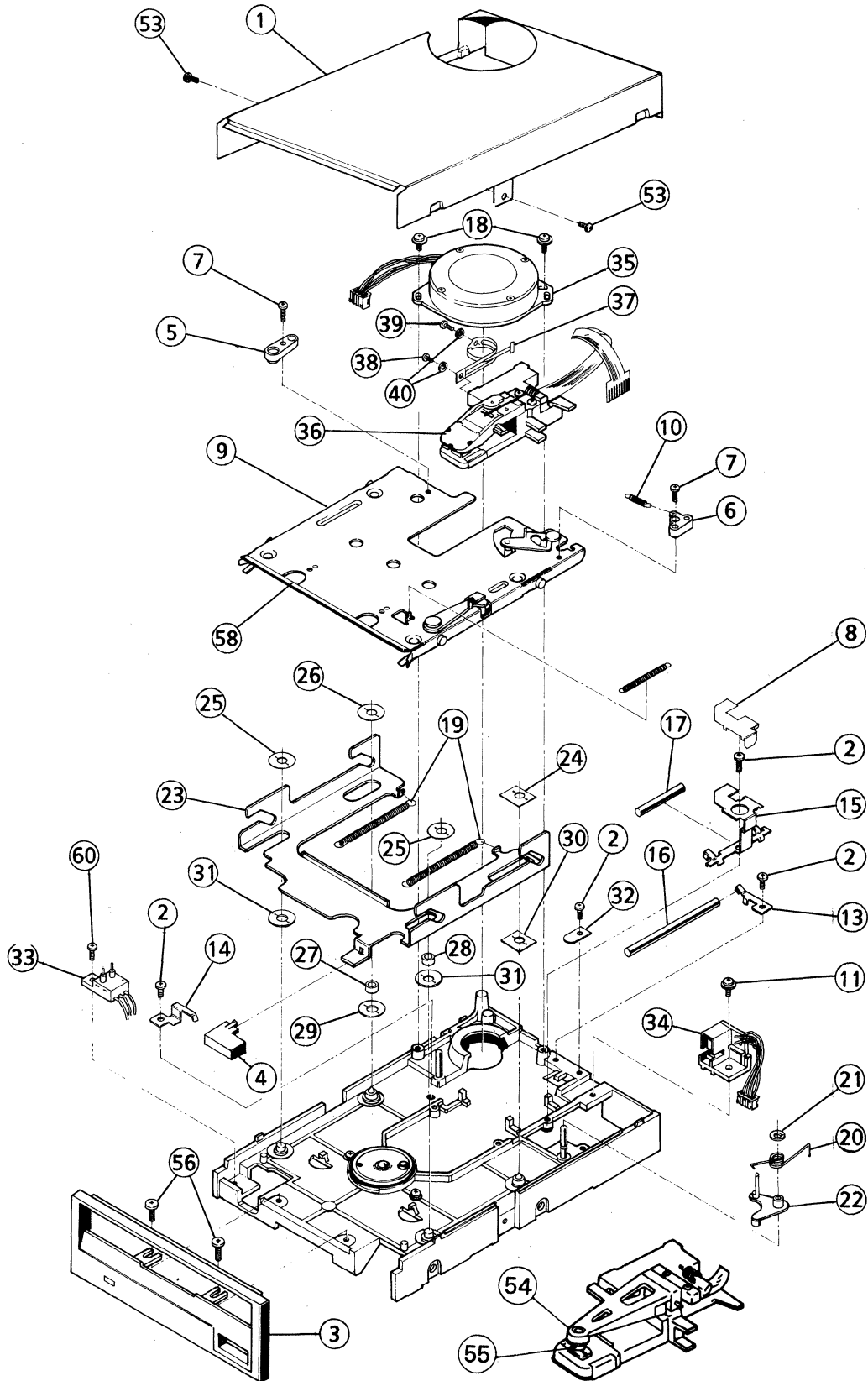

Fig. 11.14 Removing the Track 0 Sensor Assembly

12. TEST POINT



13. EXPLODED VIEW - 1



EXPLODED VIEW - 2

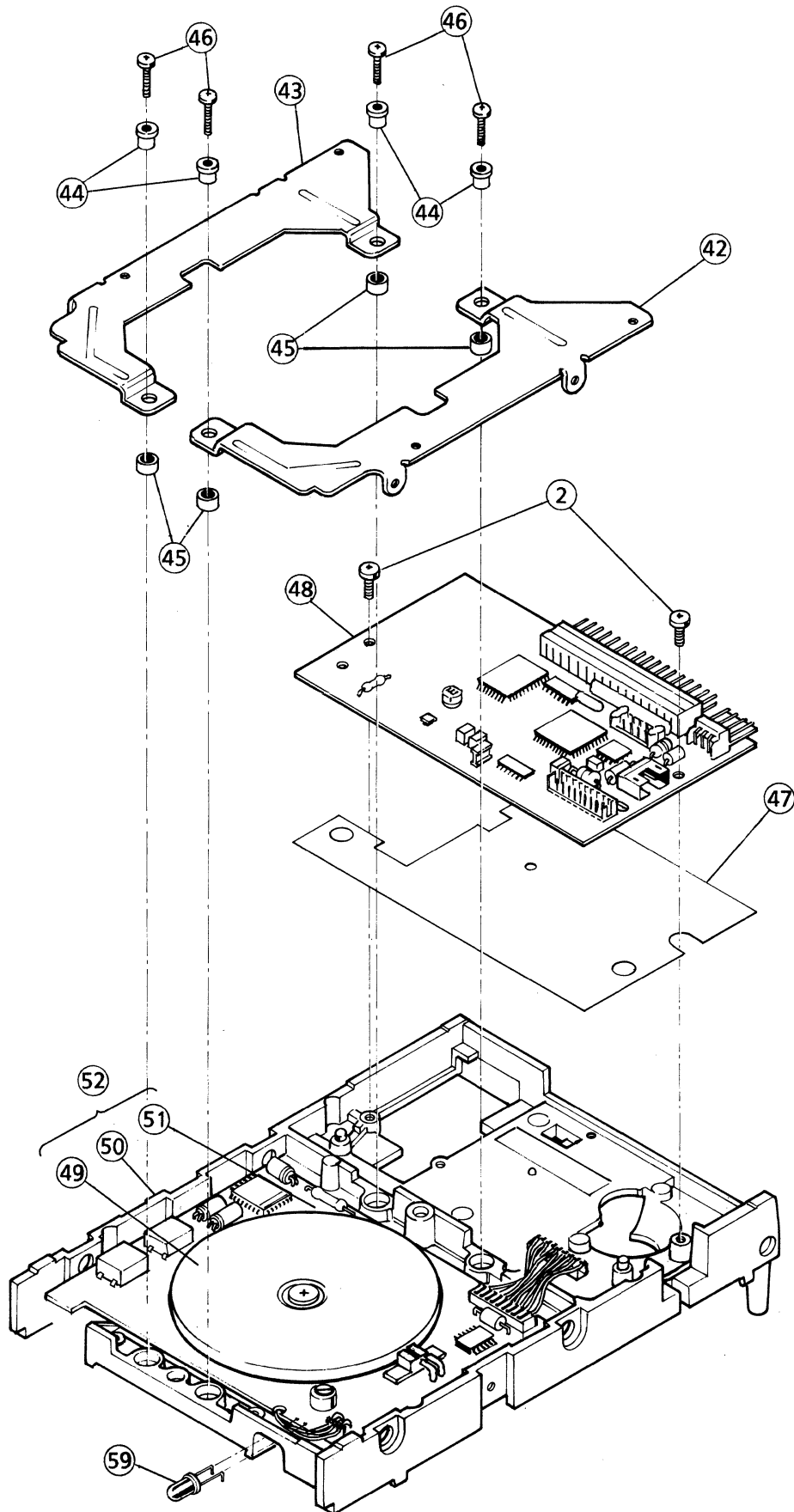

14. REPLACEMENT PARTS LIST

MODEL : JU - 314 - 021

Ref.No.	Part No.	Part Name & Description	Per Set (pcs.)	Recommend Service Parts per 1,000 Units
1	YTF5E00562B3	Cover	1	
2	XSB25 + 5FX	Screw (M2.5x5 Bind)	6	
3	YTF7K02200B4	Front Panel Assembly	1	3
4	YTF6J00572B4	Button (For Eject)	1	3
5	YTF4H01602B4	Lever (For Holder Mounting)	1	
6	YTF4H01614B4	Lever (For Auto Shutter)	1	
7	XSN2 + 5FX	Screw (M2 x 5Pan Head)	2	
8	YTF2C03191B4	FPC Clamp	1	
9	YTF7K01868B3	Holder Assembly	1	
10	YJF4J01594B4	Spring (For Auto Shutter)	1	
11	XYN25 + B5FX	Screw (M2.5 x 5 Sems)	1	
13	YTF2C02781B4	Clamp (End)	1	
14	YTF2C02792B4	Clamp(Left)	1	
15	YTF2C02802B4	Clamp (Right)	1	
16	YTF4H01470B4	Shaft (Long)	1	
17	YTF4H01480B4	Shaft (Short)	1	
18	YTF1E00411B4	Screw (For Stepper Motor Mounting)	2	
19	YTF4J00861B4	Spring (For Eject Lever)	2	
20	YTF4J02190B4	Spring (For Trigger Lever)	1	
21	YTF1K00441B4	Stopper A	1	
22	YTF7K01853B4	Lever Assembly (Trigger)	1	
23	YJUF363EJT1	Lever (For Eject,Attached Button)	1	
24	YTF1K00530B4	Stopper F	1	
25	YTF1K00391B4	Stopper C	2	
26	YTF1K00510B4	Stopper E	1	
27	YTF4S00800B4	Roller (For Eject)	1	
28	YTF4S01680B4	Roller (For Eject)	1	
29	YTF1K00121B4	Washer	1	
30	YTF1K00363B4	Washer B	1	
31	YTF1K00370B4	Washer C	2	
32	YTF3D04830B4	Limiter (TRKφ)	1	
33	YTD2ZP -24	Micro-Switch (For Disk Detect)	1	1
34	YTUFS363T0	Sensor Assembly (For TRKφ)	1	1
35*	YTFMD00653B4	Stepper Motor	1	2
37*	YTF7K01843B3	Steel Belt Assembly	1	
38*	YTF1E00421B4	Screw (For Steelbelt & Head Mounting)	1	
39*	XYN2 + 3FN	Screw (For Steelbelt & Pulley Mounting)	1	
40*	LPW2 - 0.25	Washer (For Steelbelt & Pulley Mounting)	2	
42	YTUFS363BK-R	Bracket Assembly (Right)	1	
43	YTUFS363BK-L	Bracket Assembly(Left)	1	
44	YTF2P03050B4	Collar (For Bracket)	4	
45	YTF2P03460B4	Spacer (For Bracket)	4	
46	XSB25 + 10FX	Screw (M2.5 x 10 Sems)	4	
47	YTF2P03291B4	Insulating Paper	1	
48	YTUF314PKCNE	Control Print Circuit Board Assembly	1	1
52	YTUF363DM-2	Base D-Motor Assembly(49 + 50 + 51	1	2
53	YTF1E00600B4	Screw (For Cover)	2	
54*	YTUF313HD	Head Assembly	1	2
55	YTUFS322LP	Pad Assembly	1	
56	YTF1E00540B4	Screw (For Front Panel)	2	
58	YTF5D00790B4	Holder Sheet (Black)	1	
59	LN28RP	LED (On Motor PCB)	1	1
60	YTF1E00550B4	Screw (For Micro-Switch)	1	

- Caution :
1. PCB Assembly is produced to order during the production period only.
 2. When you order the aforementioned parts, be sure to specify "Part No." of the parts ordered.
 3. When replacing the parts marked with *, steel belt assembly and steel belt fixing jigs are required.

MODEL : JU - 324 - 021

Ref.No.	Part No.	Part Name & Description	Per Set (pcs.)	Recommend Service Parts per 1,000 Units
1	YTF5E00562B3	Cover	1	
2	XSB25 + 5FX	Screw (M2.5x5 Bind)	6	
3	YTF7K02200B4	Front Panel Assembly	1	3
4	YTF6J00572B4	Button (For Eject)	1	3
5	YTF4H01602B4	Lever (For Holder Mounting)	1	
6	YTF4H01614B4	Lever (For Auto Shutter)	1	
7	XSN2 + 5FX	Screw (M2 x 5Pan Head)	2	
8	YTF2C03191B4	FPC Clamp	1	
9	YTF7K01868B3	Holder Assembly	1	
10	YJF4J01594B4	Spring (For Auto Shutter)	1	
11	XYN25 + B5FX	Screw (M2.5 x 5 Sems)	1	
13	YTF2C02781B4	Clamp (End)	1	
14	YTF2C02792B4	Clamp(Left)	1	
15	YTF2C02802B4	Clamp (Right)	1	
16	YTF4H01470B4	Shaft (Long)	1	
17	YTF4H01480B4	Shaft (Short)	1	
18	YTF1E00411B4	Screw (For Stepper Motor Mounting)	2	
19	YTF4J00861B4	Spring (For Eject Lever)	2	
20	YTF4J02190B4	Spring (For Trigger Lever)	1	
21	YTF1K00441B4	Stopper A	1	
22	YTF7K01853B4	Lever Assembly (Trigger)	1	
23	YJUF363EJT1	Lever (For Eject,Attached Button)	1	
24	YTF1K00530B4	Stopper F	1	
25	YTF1K00391B4	Stopper C	2	
26	YTF1K00510B4	Stopper E	1	
27	YTF4S00800B4	Roller (For Eject)	1	
28	YTF4S01680B4	Roller (For Eject)	1	
29	YTF1K00121B4	Washer	1	
30	YTF1K00363B4	Washer B	1	
31	YTF1K00370B4	Washer C	2	
32	YTF3D04830B4	Limitter (TRKφ)	1	
33	YTD2ZP -24	Micro-Switch (For Disk Detect)	1	1
34	YTUF5363T0	Sensor Assembly (For TRKφ)	1	1
35*	YTFMD00653B4	Stepper Motor	1	2
37*	YTF7K01843B3	Steel Belt Assembly	1	
38*	YTF1E00421B4	Screw (For Steelbelt & Head Mounting)	1	
39*	XYN2 + 3FN	Screw (For Steelbelt & Pulley Mounting)	1	
40*	LPW2 - 0.25	Washer (For Steelbelt & Pulley Mounting)	2	
42	YTUF5363BK-R	Bracket Assembly (Right)	1	
43	YTUF5363BK-L	Bracket Assembly(Left)	1	
44	YTF2P03050B4	Collar (For Bracket)	4	
45	YTF2P03460B4	Spacer (For Bracket)	4	
46	XSB25 + 10FX	Screw (M2.5 x 10 Sems)	4	
47	YTF2P03291B4	Insulating Paper	1	
48	YTUF364PKCNE	Control Print Circuit Board Assembly	1	1
52	YTUF363DM-2	Base D-Motor Assembly(49 + 50 + 51	1	2
53	YTF1E00600B4	Screw (For Cover)	2	
54*	YTUF323HD	Head Assembly	1	2
55	YTUF5322LP	Pad Assembly	1	
56	YTF1E00540B4	Screw (For Front Panel)	2	
58	YTF5D00790B4	Holder Sheet (Black)	1	
59	LN28RP	LED (On Motor PCB)	1	1
60	YTF1E00550B4	Screw (For Micro-Switch)	1	

- Caution :
1. PCB Assembly is produced to order during the production period only.
 2. When you order the aforementioned parts, be sure to specify "Part No." of the parts ordered.
 3. When replacing the parts marked with *,steel belt assembly and steel belt fixing jigs are required.

MODEL : JU - 364 - 141

Ref.No.	Part No.	Part Name & Description	Per Set (pcs.)	Recommend Service Parts per 1,000 Units
1	YTF5E00562B3	Cover	1	
2	XSB25 + 5FX	Screw (M2.5x5 Bind)	6	
3	YTF7K02200B4	Front Panel Assembly	1	3
4	YTF6J00572B4	Button (For Eject)	1	3
5	YTF4H01602B4	Lever (For Holder Mounting)	1	
6	YTF4H01614B4	Lever (For Auto Shutter)	1	
7	XSN2 + 5FX	Screw (M2 x 5Pan Head)	2	
8	YTF2C03191B4	FPC Clamp	1	
9	YTF7K01868B3	Holder Assembly	1	
10	YJF4J01594B4	Spring (For Auto Shutter)	1	
11	XYN25 + B5FX	Screw (M2.5 x 5 Sems)	1	
13	YTF2C02781B4	Clamp (End)	1	
14	YTF2C02792B4	Clamp(Left)	1	
15	YTF2C02802B4	Clamp (Right)	1	
16	YTF4H01470B4	Shaft (Long)	1	
17	YTF4H01480B4	Shaft (Short)	1	
18	YTF1E00411B4	Screw (For Stepper Motor Mounting)	2	
19	YTF4J00861B4	Spring (For Eject Lever)	2	
20	YTF4J02190B4	Spring (For Trigger Lever)	1	
21	YTF1K00441B4	Stopper A	1	
22	YTF7K01853B4	Lever Assembly (Trigger)	1	
23	YJUF363EJT1	Lever (For Eject,Attached Button)	1	
24	YTF1K00530B4	Stopper F	1	
25	YTF1K00391B4	Stopper C	2	
26	YTF1K00510B4	Stopper E	1	
27	YTF4S00800B4	Roller (For Eject)	1	
28	YTF4S01680B4	Roller (For Eject)	1	
29	YTF1K00121B4	Washer	1	
30	YTF1K00363B4	Washer B	1	
31	YTF1K00370B4	Washer C	2	
32	YTF3D04830B4	Limitter (TRKφ)	1	
33	YTD2ZP -24	Micro-Switch (For Disk Detect)	1	1
34	YTUF5363T0	Sensor Assembly (For TRKφ)	1	1
35*	YTFMD00653B4	Stepper Motor	1	2
36*	YTUF363HD	Head Assembly	1	2
37*	YTF7K01843B3	Steel Belt Assembly	1	
38*	YTF1E00421B4	Screw (For Steelbelt & Head Mounting)	1	
39*	XYN2 + 3FN	Screw (For Steelbelt & Pulley Mounting)	1	
40*	LPW2 - 0.25	Washer (For Steelbelt & Pulley Mounting)	2	
42	YTUF5363BK-R	Bracket Assembly (Right)	1	
43	YTUF5363BK-L	Bracket Assembly(Left)	1	
44	YTF2P03050B4	Collar (For Bracket)	4	
45	YTF2P03460B4	Spacer (For Bracket)	4	
46	XSB25 + 10FX	Screw (M2.5 x 10 Sems)	4	
47	YTF2P03291B4	Insulating Paper	1	
48	YTUF364PKCNE	Control Print Circuit Board Assembly	1	1
52	YTUF363DM-2	Base D-Motor Assembly(49 + 50 + 51	1	2
53	YTF1E00600B4	Screw (For Cover)	2	
56	YTF1E00540B4	Screw (For Front Panel)	2	
58	YTF5D00790B4	Holder Sheet (Black)	1	
59	LN28RP	LED (On Motor PCB)	1	1
60	YTF1E00550B4	Screw (For Micro-Switch)	1	

- Caution :
1. PCB Assembly is produced to order during the production period only.
 2. When you order the aforementioned parts, be sure to specify "Part No." of the parts ordered.
 3. When replacing the parts marked with *,steel belt assembly and steel belt fixing jigs are required.

MODEL : JU - 314 - 021
Component Side (Top)

Ref.No.	Part No.	Part Name & Description	Per Set (pcs.)	Recommend Service Parts per 1,000 Units
C9,10	ECEA1CK5100	Electrolyte Capacitor	2	
C5,16,18	FCJ00080B400	Ceramic Capacitor	3	
C6,11,12	RPE122F104Z	Ceramic Capacitor	3	
CN	YTA020000805	Connector (Short Plug)	2	
CN	YTA142001801	Connector (Short Plug Connector)	1	
CN5	B09-DR-5	Connector	1	
CN3	FJC00150B4	Connector	1	
CN6	ILS4P52T2EF	Connector	1	
CN2	171826-4	Connector (Power)	1	
CN1	34PA-2. 5D53	Connector (I/O Connector)	1	
CN6,7	4P52L225EFK	Connector	1	
L6,7	BL01RN1A62	Choke Coil (Ferrite Beads)	2	1
L1	ELEBD330KA	Choke Coil	1	1
L2	ELEBD681KA	Choke Coil	1	1
R25	ERG15J151	Metal Oxide Film Resistor	1	
X1	YJCSA4. 00MG	Resonator	1	1
VR1	EVMQ0G01KB24	Variable Resistor	1	1
IR1	RGLD9X102J	Block Resistor	1	
C4	ECUV1H152KBM	Chip Capacitor	1	
D6,7	MA159-TX	Chip Diode	2	2
E	YJFPK01271B3	PCB	1	
IC	HA13421AMP	LSI	1	2
IC	HA16642MP	IC	1	2
IC	HA16643MP	LSI	1	2
L5	FNC00030B424	Low-Frequency Coil	1	1
L3,4	FNC00030B426	Low-Frequency Coil	2	1
R22,23	MCR18EZHG332	Chip Resistor	2	
R35	MCR18EZHG272	Chip Resistor	1	
R36	MCR18EZHJ221	Chip Resistor	1	
R7,8,9	MCR18EZHJ331	Chip Resistor	3	
R6	MCR18EZHJ393	Chip Resistor	1	
R45	MCR18EZHJ000	Chip Resistor	1	

Solder Side (Bottom)

Ref.No.	Part No.	Part Name & Description	Per Set (pcs.)	Recommend Service Parts per 1,000 Units
C1,2,3	ECUV1H152KBM	Chip Capacitor	3	
C7,8	FCC00010B424	Chip Capacitor	2	
C13,20	FCC00010B440	Chip Capacitor	2	
C14	FCC00010B448	Chip Capacitor	1	
C21	FCC00010B456	Chip Capacitor	1	
C19,22,23	FCC00020B401	Chip Capacitor	3	
C24	FCC00030B412	Chip Capacitor	1	
ID1,2,3,4	DAN202KT-96	Diode Array	4	2
ID5	DAN202KT-97	Diode Array	1	2
Q1	2SD601-RTX	Transistor	1	2
R20,21	MCR18EZHG103	Chip Resistor	2	
R18	MCR18EZHG183	Chip Resistor	1	
R29,30	MCR18EZHG222	Chip Resistor	2	
R19	MCR18EZHG392	Chip Resistor	1	
R41,42	MCR18EZHJ000	Chip Resistor	2	
R40	MCR18EZHJ103	Chip Resistor	1	
R11	MCR18EZHJ105	Chip Resistor	1	
R10	MCR18EZHJ151	Chip Resistor	1	
R32	MCR18EZHJ271	Chip Resistor	1	
R27,28	MCR18EZHJ391	Chip Resistor	2	
R2,3	MCR18EZHJ393	Chip Resistor	2	
R24	MCR18EZHJ472	Chip Resistor	1	
R31,37	MCR18EZHJ473	Chip Resistor	2	
R1	MCR18EZHJ822	Chip Resistor	1	

MODEL : JU - 324 - 021
Component Side (Top)

Ref.No.	Part No.	Part Name & Description	Per Set (pcs.)	Recommend Service Parts per 1,000 Units
C9,10	ECEA1CK5100	Electrolyte Capacitor	2	
C27	ECQV1H274JZ	Film Capacitor	1	
C5,16,18	FCJ00080B400	Ceramic Capacitor	3	
C6,11,12	RPE122F104Z	Ceramic Capacitor	3	
CN	YTA020000805	Connector (Short Plug)	2	
CN	YTA142001801	Connector (Short Plug Connector)	1	
CN5	B09-DR-5	Connector	1	
CN3	FJC00150B4	Connector	1	
CN6	ILS4PS2T2EF	Connector	1	
CN2	171826-4	Connector (Power)	1	
CN1	34PA-2. 5D53	Connector (I/O Connector)	1	
CN4	4PS2L225EFK	Connector	1	
L6,7	BL01RN1A62	Choke Coil (Ferrite Beads)	2	1
L1	ELEBD330KA	Choke Coil	1	1
L2	ELEBD681KA	Choke Coil	1	1
R25	ERD50TJ681	Carbon Resistor	1	
X1	YJCSA4. 00MG	Resonator	1	1
VR1	EVMQ0G01KB24	Variable Resistor	1	1
IR1	RGLD9X102J	Block Resistor	1	
C4	ECUV1H152KBM	Chip Capacitor	1	
D6,7	MA159-TX	Chip Diode	2	2
E	YJFPK01271B3	PCB	1	
IC	HA13421AMP	LSI	1	2
IC	HA16642MP	IC	1	2
IC	HA16643MP	LSI	1	2
L5	FNC00030B424	Low-Frequency Coil	1	1
L3,4	FNC00030B426	Low-Frequency Coil	2	1
R22,23	MCR18EZHG332	Chip Resistor	2	
R35	MCR18EZHG682	Chip Resistor	1	
R36	MCR18EZHJ221	Chip Resistor	1	
R7,8,9	MCR18EZHJ331	Chip Resistor	3	
R6	MCR18EZHJ393	Chip Resistor	1	

Solder Side (Bottom)

Ref.No.	Part No.	Part Name & Description	Per Set (pcs.)	Recommend Service Parts per 1,000 Units
C1,2,3	ECUV1H152KBM	Chip Capacitor	3	
C7,8	FCC00010B424	Chip Capacitor	2	
C13,20	FCC00010B440	Chip Capacitor	2	
C14	FCC00010B448	Chip Capacitor	1	
C21	FCC00010B456	Chip Capacitor	1	
C19,22,23	FCC00020B401	Chip Capacitor	3	
C24	FCC00030B412	Chip Capacitor	1	
ID1,2,3,4	DAN202KT-96	Diode Array	4	2
ID5	DAN202KT-97	Diode Array	1	2
Q1	2SD601-TX	Transistor	1	2
R20,21	MCR18EZHG103	Chip Resistor	2	
R18	MCR18EZHG183	Chip Resistor	1	
R29,30	MCR18EZHG222	Chip Resistor	2	
R	MCR18EZHG392	Chip Resistor	1	
R41,42	MCR18EZHJ000	Chip Resistor	2	
R40	MCR18EZHJ103	Chip Resistor	1	
R11	MCR18EZHJ105	Chip Resistor	1	
R10	MCR18EZHJ151	Chip Resistor	1	
R32	MCR18EZHJ271	Chip Resistor	1	
R27,28	MCR18EZHJ391	Chip Resistor	2	
R2,3	MCR18EZHJ393	Chip Resistor	2	
R24	MCR18EZHJ472	Chip Resistor	1	
R31,37	MCR18EZHJ473	Chip Resistor	2	
R1	MCR18EZHJ822	Chip Resistor	1	

MODEL : JU - 364 - 141
Component Side (Top)

Ref.No.	Part No.	Part Name & Description	Per Set (pcs.)	Recommend Service Parts per 1,000 Units
C9,10	ECEA1CK5100	Electrolyte Capacitor	2	
C27	ECQV1H274JZ	Film Capacitor	1	
C5,16,18	FCJ00080B400	Ceramic Capacitor	3	
C6,11,12	RPE122F104Z	Ceramic Capacitor	3	
CN	YTA020000805	Connector (Short Plug)	2	
CN	YTA142001801	Connector (Short Plug Connector)	1	
CN5	B09-DR-S	Connector	1	
CN3	FJC00150B4	Connector	1	
CN6	ILS4PS2T2EF	Connector	1	
CN2	171826-4	Connector (Power)	1	
CN1	34PA-2.5D53	Connector (I/O Connector)	1	
CN4	4PS2L225EFK	Connector	1	
L6,7	BL01RN1A62	Choke Coil (Ferrite Beads)	2	1
L1	ELEBD330KA	Choke Coil	1	1
L2	ELEBD681KA	Choke Coil	1	1
R25	ERD50TJ681	Carbon Resistor	1	
X1	YJCSA4.00MG	Resonator	1	1
VR1	EVMQ0G01KB24	Variable Resistor	1	1
IR1	RGLD9X102J	Block Resistor	1	
C4	ECUV1H152KBM	Chip Capacitor	1	
D6,7	MA159-TX	Chip Diode	2	2
E	YJFPK01271B3	PCB	1	
IC	HA13421AMP	LSI	1	2
IC	HA16642MP	IC	1	2
IC	HA16643MP	LSI	1	2
L5	FNC00030B424	Low-Frequency Coil	1	1
L3,4	FNC00030B426	Low-Frequency Coil	2	1
R22,23	MCR18EZHG332	Chip Resistor	2	
R35	MCR18EZHG682	Chip Resistor	1	
R36	MCR18EZHJ221	Chip Resistor	1	
R7,8,9	MCR18EZHJ331	Chip Resistor	3	
R6	MCR18EZHJ393	Chip Resistor	1	

Solder Side (Bottom)

Ref.No.	Part No.	Part Name & Description	Per Set (pcs.)	Recommend Service Parts per 1,000 Units
C1,2,3	ECUV1H152KBM	Chip Capacitor	3	
C7,8	FCC00010B424	Chip Capacitor	2	
C13,20	FCC00010B440	Chip Capacitor	2	
C14	FCC00010B448	Chip Capacitor	1	
C21	FCC00010B456	Chip Capacitor	1	
C19,22,23	FCC00020B401	Chip Capacitor	3	
C24	FCC00030B412	Chip Capacitor	1	
ID1,2,3,4	DAN202KT-96	Diode Array	4	2
ID5	DAN202KT-97	Diode Array	1	2
Q1	2SD601-TX	Transistor	1	2
R20,21	MCR18EZHG103	Chip Resistor	2	
R18	MCR18EZHG183	Chip Resistor	1	
R29,30	MCR18EZHG222	Chip Resistor	2	
R	MCR18EZHG392	Chip Resistor	1	
R41,42	MCR18EZHJ000	Chip Resistor	2	
R40	MCR18EZHJ103	Chip Resistor	1	
R11	MCR18EZHJ105	Chip Resistor	1	
R10	MCR18EZHJ151	Chip Resistor	1	
R32	MCR18EZHJ271	Chip Resistor	1	
R27,28	MCR18EZHJ391	Chip Resistor	2	
R2,3	MCR18EZHJ393	Chip Resistor	2	
R24	MCR18EZHJ472	Chip Resistor	1	
R31,37	MCR18EZHJ473	Chip Resistor	2	
R1	MCR18EZHJ822	Chip Resistor	1	

15. SCHEMATIC DIAGRAM OF CONTROL BOARD [JU-314]

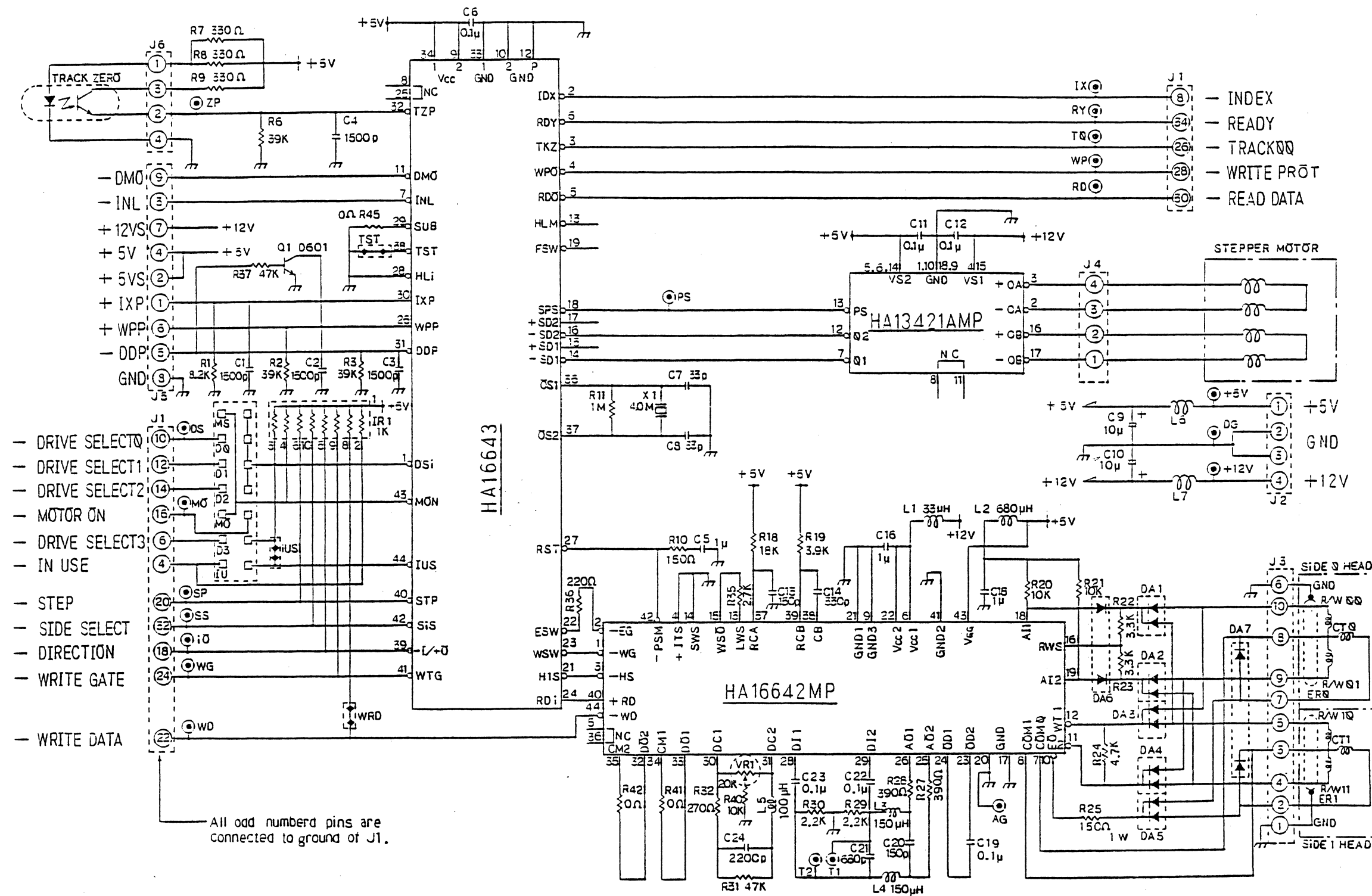

SCHEMATIC DIAGRAM OF CONTROL BOARD [JU-324/364]

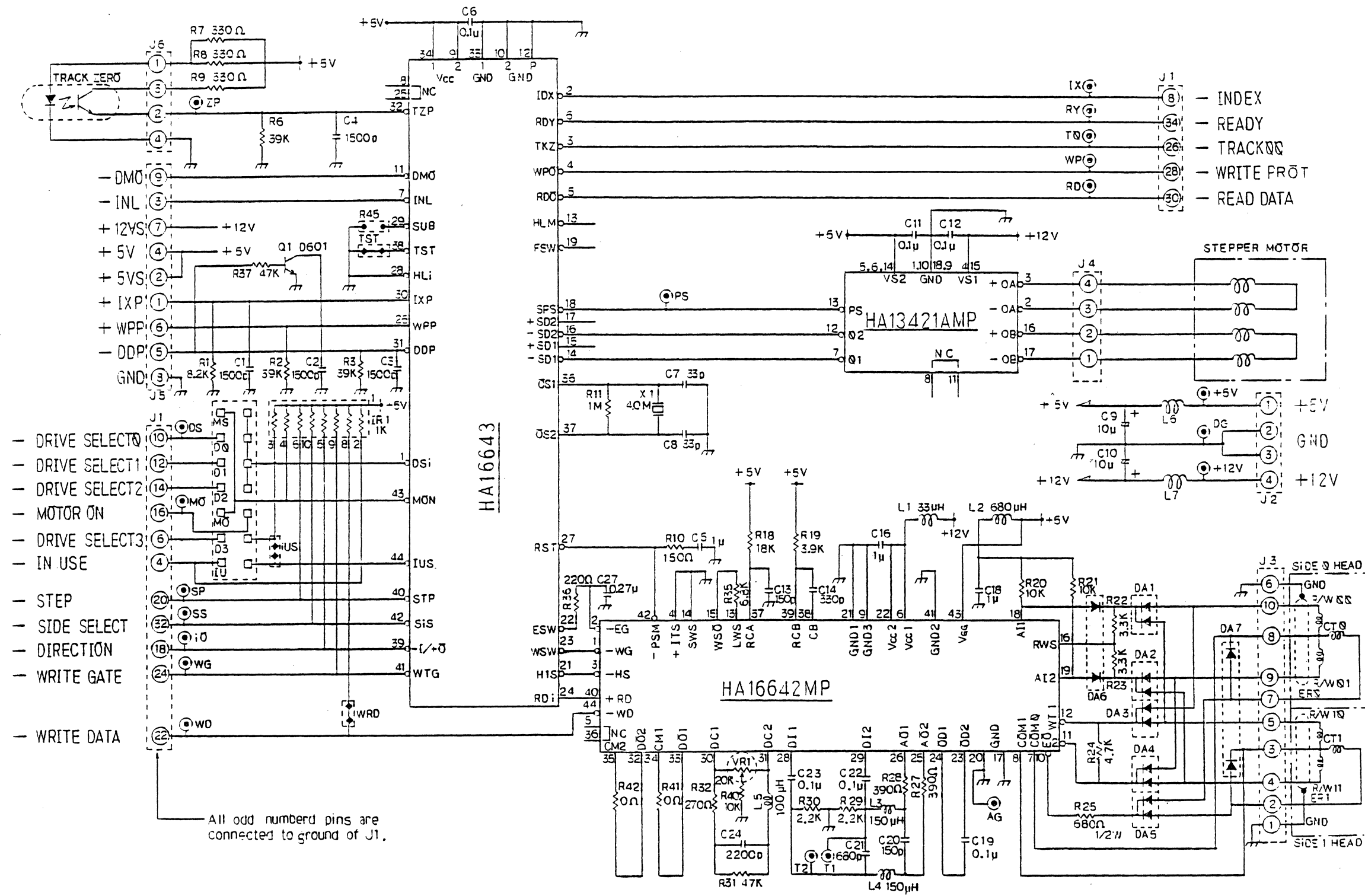

16. CIRCUIT BOARD

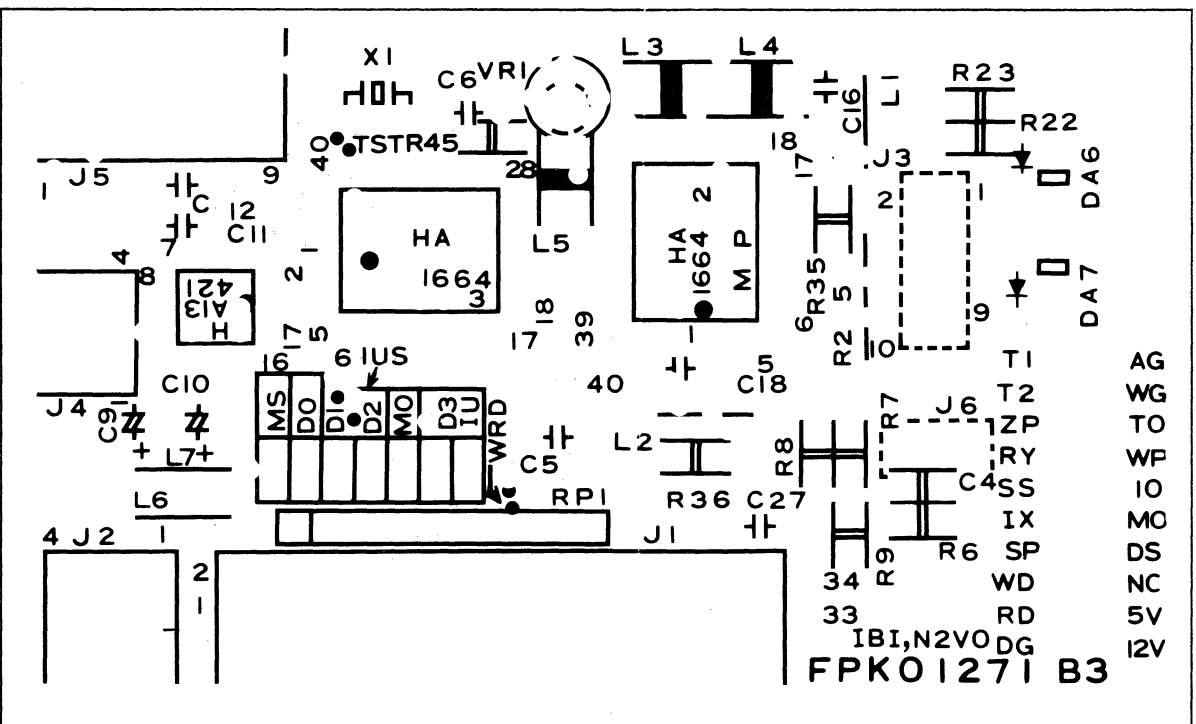

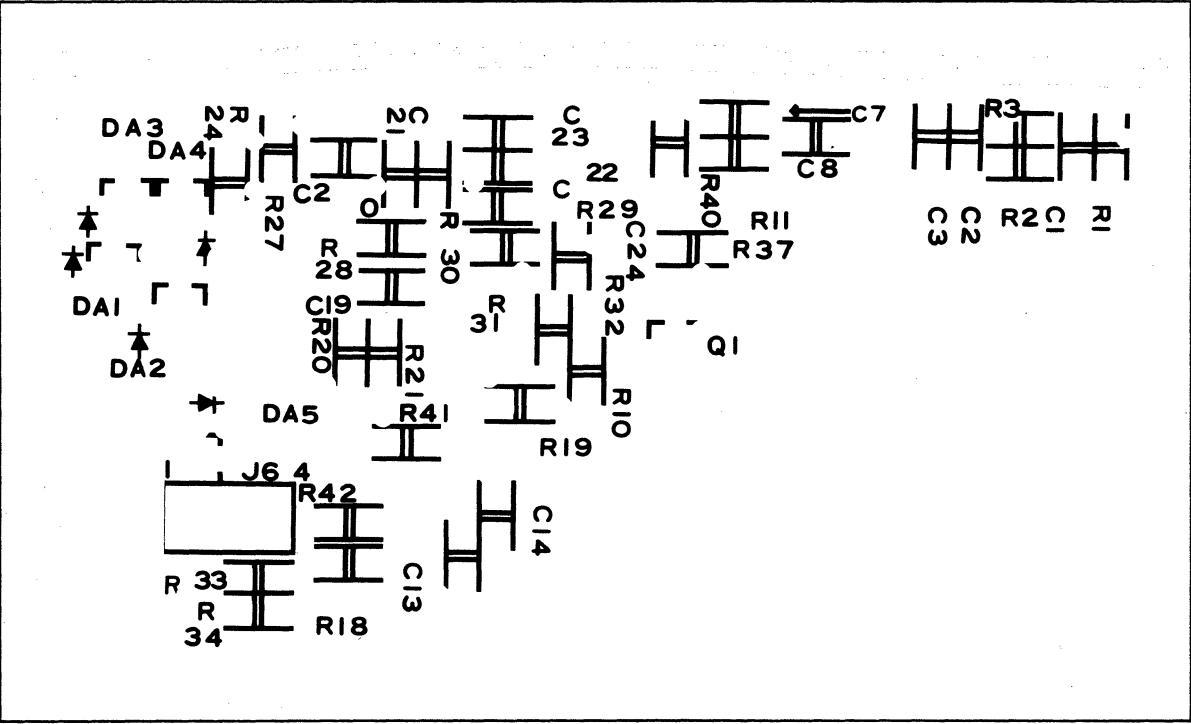

Solder Side (Bottom)

Technical Publications Suggestion Form

We would appreciate your comments and suggestions for improving this publication

Technical
Publications
Suggestion
Form

PUBLICATION NO :	TITLE :	DATE :
WHAT IS YOUR OVERALL RATING THIS PUBLICATION? <input type="checkbox"/> VERY GOOD <input type="checkbox"/> FAIR <input type="checkbox"/> VERY POOR <input type="checkbox"/> GOOD <input type="checkbox"/> POOR		
IS THE MATERIAL PRESENTED EFFECTIVELY? <input type="checkbox"/> WELL ORGANIZED <input type="checkbox"/> FULLY COVERED <input type="checkbox"/> CLEAR <input type="checkbox"/> CORRECT <input type="checkbox"/> WELL ILLUSTRATED		

Panasonic

COMMENTS :

PLEASE PRINT : NAME, ADDRESS AND PHONE NO.
--

PLEASE MAIL TO : _____

Matsushita Communication Industrial Co., Ltd.
Memory Systems Division
3-1, 4-chome, Tsunashima-Higashi
Kohoku-ku, Yokohama 223 JAPAN