

InfoServer Client for OpenVMS

digital

Installation Guide

Part Number: AA-PF4DB-TE

InfoServer Client for OpenVMS

Installation Guide

Order Number: AA-PF4DB-TE

November 1992

This manual explains how to install InfoServer Client for OpenVMS software, which enables OpenVMS clients to access device services provided by Infoserver systems on a local area network (LAN). These services include compact discs, read/write and mageto-optical disks, and tape devices.

Revision/Update Information: This is a new manual.

Software Version: InfoServer Software Version 2.0 or later

Operating System and Version: OpenVMS Version 5.0 or later

)
Digital Equipment Corporation
Maynard, Massachusetts

November 1992

The information in this document is subject to change without notice and should not be construed as a commitment by Digital Equipment Corporation. Digital Equipment Corporation assumes no responsibility for any errors that may appear in this document.

The software described in this document is furnished under a license and may be used or copied only in accordance with the terms of such license.

No responsibility is assumed for the use or reliability of software on equipment that is not supplied by Digital Equipment Corporation or its affiliated companies.

Restricted Rights: Use, duplication, or disclosure by the U.S. Government is subject to restrictions as set forth in subparagraph (c)(1)(ii) of the Rights in Technical Data and Computer Software clause at DFARS 252.227-7013.

© Digital Equipment Corporation 1992.

The following are trademarks of Digital Equipment Corporation: DEC, DECnet, DIGITAL, LASTport, VAX, VAXcluster, VAXserver, VAXstation, OpenVMS, and the DIGITAL logo.

This document was prepared using VAX DOCUMENT, Version 2.0.

Contents

Preface	v
1 InfoServer and InfoServer Client for OpenVMS	
1.1 InfoServer Functions	1-1
1.2 InfoServer Client for OpenVMS Functions	1-3
2 Preparing to Install InfoServer Client for OpenVMS	
2.1 Required Operating System Components	2-1
2.2 Prerequisite Hardware	2-1
2.3 License Registration	2-2
2.4 Installation Procedure Requirements	2-2
2.4.1 Privileges and Disk Space	2-2
2.4.2 Process Account Quotas	2-3
2.4.3 VMSINSTAL Requirements	2-4
2.4.4 Backing Up Your System Disk	2-5
2.4.5 InfoServer Client for OpenVMS Requirements	2-5
3 Installing InfoServer Client for OpenVMS	
3.1 Running the Installation Procedure	3-1
3.2 Error Recovery	3-7
4 After Installing InfoServer Client for OpenVMS	
4.1 Running the Installation Verification Procedure Separately	4-1
4.2 Editing the System Files	4-1
4.2.1 Startup Restrictions: PCSA and RSM	4-2
4.2.2 Startup Restrictions: SYSMAN	4-2
4.3 User Account Requirements	4-2
4.3.1 Privileges	4-2
4.3.2 User Account Quotas	4-3

4.4	Determining and Reporting Problems	4-3
-----	--	-----

A Files and Logical Names Installed on Your System

A.1	File Names	A-1
A.2	Logical Names	A-2

B Sample Installation: Run-Time Kit

Index

Figures

1-1	InfoServer System Serving Clients	1-3
-----	---	-----

Tables

2-1	Disk Space Requirements	2-3
2-2	Process Account Quotas for the Installing Account	2-3

Preface

Document Purpose

This manual explains how to install InfoServer Client for OpenVMS software.

Intended Audience

This manual is intended for OpenVMS system managers and InfoServer managers.

Related Documents

The following documents provide information about InfoServer systems and InfoServer system management:

- The *InfoServer 100 Installation and Owner's Guide* and the *InfoServer 150 Installation and Owner's Guide* explain how to install and configure InfoServer hardware.
- The *InfoServer System Operations Guide* explains how to manage an InfoServer system.
- The *InfoServer Client for OpenVMS LASTCP and LADCP Utilities* manual describes the LASTCP and LADCP utilities. You use the LASTCP utility to configure the LASTport transport protocol on your OpenVMS system, and you use the LADCP utility to manage InfoServer device services.

Document Structure

This guide is organized as follows:

- Chapter 1 introduces InfoServer and InfoServer Client for OpenVMS functions.
- Chapter 2 describes the operating system and hardware requirements for InfoServer Client for OpenVMS installation and related procedures that you complete before installing InfoServer Client for OpenVMS software.

- Chapter 3 describes the installation procedures for local, server, and client installations.
- Chapter 4 describes the Installation Verification Procedure (IVP) and any post-installation procedures that you must complete to use InfoServer Client for OpenVMS.
- Appendix A list the files installed on your system and the logical names defined.
- Appendix B contains a sample installation procedure.

Conventions

The following conventions are used in this manual:

Ctrl/x	A sequence such as Ctrl/x indicates that you must hold down the key labeled Ctrl while you press another key or a pointing device button.
Return	In examples, a key name is shown enclosed in a box to indicate that you press a key on the keyboard. (In text, a key name is not enclosed in a box.)
.	A vertical ellipsis indicates the omission of items from a code example or command format; the items are omitted because they are not important to the topic being discussed.
()	In format descriptions, parentheses indicate that, if you choose more than one option, you must enclose the choices in parentheses.
{ }	In format descriptions, choices between two or more options are enclosed in braces ({}). Choices are separated by a vertical bar ().
[]	Brackets in installation dialog enclose default answers. To choose the default, press the Return key. To specify another answer, type the answer after the question and press the Return key. In format descriptions, brackets indicate that whatever is enclosed within the brackets is optional; you can select none, one, or all of the choices. (Brackets are not, however, optional in the syntax of a directory name in a file specification or in the syntax of a substring specification in an assignment statement.)

Red ink indicates information that you must enter from the keyboard or a screen object that you must choose or click on.

For online versions of the book, user input is shown in **bold**.

boldface text

Boldface text represents the introduction of a new term or the name of an argument, an attribute, or a reason.

italic text

Italic text represents information that can vary in system messages (for example, Internal error *number*).

UPPERCASE TEXT

Uppercase letters indicate that you must enter a command (for example, enter OPEN/READ), or they indicate the name of a routine, the name of a file, the name of a file protection code, or the abbreviation for a system privilege.

numbers

Unless otherwise noted, all numbers in the text are assumed to be decimal. Nondecimal radices—binary, octal, or hexadecimal—are explicitly indicated.

InfoServer and InfoServer Client for OpenVMS

This chapter presents an overview of InfoServer and InfoServer Client for OpenVMS functions.

1.1 InfoServer Functions

The InfoServer system is an Ethernet-based, high-performance, **virtual device server**. It can serve physical device media and sets of logical disk blocks to the network. Host systems running the appropriate client software can connect to virtual devices served by the InfoServer system and use them as though they are locally attached devices.

The InfoServer system is a virtual device server. Unlike a **file server**, the InfoServer system does not impose a file system on the virtual devices that it serves. This means that the InfoServer system can serve a disk with any type of on-disk file structure. The host client system itself interprets the on-disk structure, allowing each client system to use its own native file system. Multiple on-disk structures can be served by and accessed on a single InfoServer system at the same time.

The InfoServer system can perform the following functions:

- **MAKE COMPACT DISCS AVAILABLE TO CLIENTS ON THE NETWORK.**
The InfoServer system serves compact discs automatically, using their volume label as the service name when the server is booted or when compact discs are inserted into InfoServer drives. You do not have to perform any management action. Client systems simply bind to and mount the compact discs under their volume labels.

The InfoServer system can automatically serve to OpenVMS clients compact discs that are in ODS-2, High Sierra, and ISO-9660 format. Other media types can be served manually through the InfoServer management interface.

InfoServer and InfoServer Client for OpenVMS

1.1 InfoServer Functions

- MAKE SCSI TAPES AVAILABLE TO CLIENTS ON THE NETWORK.

The InfoServer system can serve SCSI tape devices to the network using service names. Client systems can connect to these tape devices and utilize them as though they were locally attached devices.

- SERVE READ/WRITE DISK PARTITIONS.

A **partition** is a logical subset of a read/write disk. A single disk can be subdivided into several partitions, each of which can be served to the network independently. To remote client systems, these partitions appear to be whole disks. For example, a client system using InfoServer Client for OpenVMS software can access InfoServer partitions and use them as though they are local hard disks.

- ACT AS AN INITIAL LOAD SYSTEM FOR OPENVMS SYSTEMS.

The InfoServer system can downline load the primary bootstrap program to OpenVMS systems, by handling maintenance operation protocol (MOP) requests. The OpenVMS system then connects back to the OpenVMS software distribution compact disc and allows the BACKUP utility to make a copy of the OpenVMS operating system savesets from the compact disc onto a read/write disk attached to the system. All subsequent OpenVMS boots are then done from the local read/write disk. See the *InfoServer System Operations Guide* for information on downline loading.

- DOWNLINE LOAD OTHER PRODUCTS.

The InfoServer system can be used to load any Ethernet product that requests a particular file name to be loaded; that is, the product does not require an NCP database entry to locate the required file. For example, X terminal clients use the InfoServer system to downline load their system software. Special MOP partitions can be created, and the desired file copied to that partition. Each InfoServer system can handle up to 100 simultaneous downline loads more efficiently than host-based downline loaders, which must start processes to assist in the load.

Figure 1–1 shows the relationship of the InfoServer system to several possible client systems. In this figure, the four compact disc drives connected to the server appear to the client systems as local devices. The VAX system and the OpenVMS workstation might be using one or two of the compact discs for software distribution and online documentation, while the RISC system might be referencing a disk partition on the InfoServer system. The X terminal boots from the InfoServer system and uses InfoServer disks for page, font, and customization files.

InfoServer and InfoServer Client for OpenVMS

1.1 InfoServer Functions

Figure 1-1 InfoServer System Serving Clients

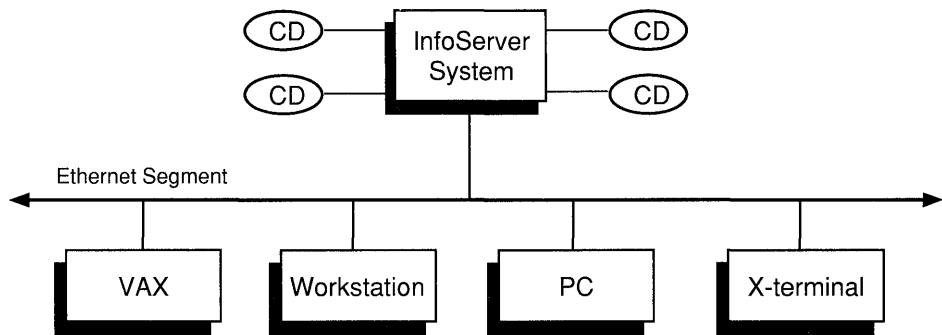

LJG-0001-OP

You can simply connect the InfoServer system to your Ethernet local area network and turn it on. After the server is initialized, or **bootstrapped**, the server software automatically makes available, or **serves**, to client systems the device media connected to it. For example, if you insert a compact disc into a server drive, the server detects this new device and automatically serves it to client systems by using the volume label as the service name.

The server bootstraps from its internal RZ read/write disk drive, on which the InfoServer software is preinstalled. Any future InfoServer software updates will be distributed on compact discs. As these new releases become available, you can install the software onto the internal RZ disk for subsequent booting.

You might want to customize server features. You can control InfoServer functions by logging into the server and entering server commands, described in the *InfoServer System Operations Guide*.

1.2 InfoServer Client for OpenVMS Functions

InfoServer Client for OpenVMS software enables clients running the OpenVMS operating system to access virtual device services offered by InfoServer systems on a local area network.

InfoServer Client for OpenVMS software components include the following:

- LASTport driver

The LASTport driver provides reliable data transfer services for its clients. It interacts with the Data Link driver and the LASTport/Disk driver as an efficient transport for a virtual device service. The LASTport driver can support other applications, such as a primitive data queueing service.

InfoServer and InfoServer Client for OpenVMS

1.2 InfoServer Client for OpenVMS Functions

- LASTport/Disk client driver

The LASTport/Disk client driver presents a standard block device interface to the system. The OpenVMS file system interacts with the LASTport/Disk client as if the LASTport/Disk client is a local disk driver. The LASTport/Disk client driver supports both raw and buffered interfaces.

- LASTport/Tape client driver

The LASTport/Disk client driver enables OpenVMS clients to access and use as local devices SCSI tapes attached to InfoServer systems.

Preparing to Install InfoServer Client for OpenVMS

This chapter discusses the preparations and requirements necessary for installing InfoServer Client for OpenVMS.

This manual applies to Version 2.2 of InfoServer Client for OpenVMS and all subsequent maintenance releases up to the next major product release.

Your bill of materials (BOM) and indented bills report (BIL) specify the number and contents of your media. Be sure to verify the contents of your kit with this information. If your kit is damaged or if you find that parts of it are missing, contact your Digital representative.

InfoServer Client for OpenVMS provides online release notes. Digital strongly recommends that you read the release notes before proceeding with the installation. For information on accessing the online release notes, see Section 3.1.

2.1 Required Operating System Components

The OpenVMS operating system comes with a variety of support options, or classes. Classes include such features as networking and RMS journaling. To use InfoServer Client for OpenVMS, your system should be running at least OpenVMS VAX Version 5.0 software that includes the Base Operating System. The InfoServer system that is serving the tape drive must be running at least Version 2.0 InfoServer Software.

For a complete list of the required classes, see the Software Support Addendum (SSA), which comes with the Software Product Description (SPD).

2.2 Prerequisite Hardware

InfoServer Client for OpenVMS requires that the system have an Ethernet device installed.

Preparing to Install InfoServer Client for OpenVMS

2.3 License Registration

2.3 License Registration

InfoServer Client for OpenVMS does not require a license to be registered with the OpenVMS License Management Facility. It is required that the InfoServer Disk Function Software be enabled on any InfoServer system that is serving disks and that the InfoServer Tape Function be enabled on any InfoServer system that is serving tapes. To see which functions your InfoServer system has enabled, refer to the *InfoServer Systems Operations Guide* included with your Version 2.0 InfoServer Software.

2.4 Installation Procedure Requirements

This section and those that follow discuss various requirements for installing InfoServer Client for OpenVMS.

The installation takes approximately 5 to 30 minutes, depending on your type of media and your system configuration.

Installing InfoServer Client for OpenVMS and running the Installation Verification Procedure (IVP) on a standalone VAXstation 2000 system takes 5 minutes.

2.4.1 Privileges and Disk Space

To install InfoServer Client for OpenVMS, you must be logged in to an account that has SETPRV or at least the following privileges:

- CMKRNL
- WORLD
- SYSPRV
- SYSNAM

Note that VMSINSTAL turns off BYPASS privilege at the start of the installation.

InfoServer Client for OpenVMS requirements for free disk storage space are different during installation and after installation. Table 2–1 summarizes the storage requirements.

Preparing to Install InfoServer Client for OpenVMS 2.4 Installation Procedure Requirements

Table 2–1 Disk Space Requirements

Kit	Blocks During Installation	Blocks After Installation
InfoServer Client for OpenVMS Version 2.2	1500	625

To determine the number of free disk blocks on the current system disk, enter the following command at the DCL prompt:

```
$
```

2.4.2 Process Account Quotas

The account you use to install InfoServer Client for OpenVMS must have sufficient quotas to enable you to perform the installation. Table 2–2 summarizes the process quotas required for the installation account.

Table 2–2 Process Account Quotas for the Installing Account

Account Quota	Value
ASTLM	24
BIOLM	18
BYTLM	18,000
DIOLM	18
ENQLM	30
FILLM	20
WSDEF	300 ¹

¹The values for WSEXT and WSQUO must be equal to or greater than the WSDEF value.

User account quotas are stored in the file SYSUAF.DAT. Use the OpenVMS Authorize Utility (AUTHORIZE) to verify and change user account quotas. First set your directory to SYS\$SYSTEM and then run AUTHORIZE:

```
$  
$  
UAF>
```

At the UAF> prompt, enter the SHOW command with an account name to check a particular account. For example:

```
UAF>
```

Preparing to Install InfoServer Client for OpenVMS

2.4 Installation Procedure Requirements

To change a quota, enter the `MODIFY` command. The following example changes the `FILLM` quota for the `SMITH` account and then exits from the utility:

```
UAF>  
UAF>
```

After you exit from the utility, the system displays messages indicating whether or not changes were made. Once the changes have been made, you must log out and log in again for the new quotas to take effect.

For more information on modifying account quotas, see the description of the Authorize Utility in the OpenVMS System Management Subkit.

2.4.3 VMSINSTAL Requirements

When you invoke `VMSINSTAL`, it checks the following:

- Whether you have set your default device and directory to `SYS$UPDATE`
- Whether you are logged in to a privileged account
- Whether you have adequate quotas for installation
- Whether DECnet is running
- Whether any users are logged in to the system

Note that `VMSINSTAL` requires that the installation account have a minimum of the following quotas:

```
ASTLM = 24  
BIOLM = 18  
BYTLM = 18,000  
DIOLM = 18  
ENQLM = 30  
FILLM = 20
```

If `VMSINSTAL` detects any problems during the installation, it notifies you and asks if you want to continue the installation. In some instances, you can enter `YES` to continue. To stop the installation process and correct the situation, enter `NO` or press the Return key. Then correct the problem and restart the installation.

Preparing to Install InfoServer Client for OpenVMS 2.4 Installation Procedure Requirements

2.4.4 Backing Up Your System Disk

At the beginning of the installation, VMSINSTAL asks if you have backed up your system disk. Digital recommends that you do a system disk backup before installing any software.

Use the backup procedures that are established at your site. For details on performing a system disk backup, see the section on the Backup Utility in the OpenVMS System Management Subkit.

2.4.5 InfoServer Client for OpenVMS Requirements

InfoServer Client for OpenVMS checks whether either PATHWORKS or Remote System Manager (RSM) has been installed on the system. The installation prints a warning message if any PATHWORKS or RSM drivers or control programs are found.

```
%ESS-W-FILFND, The following drivers were found in SYS$LOADABLE_IMAGES.  
-ESS-W-FILFND,      LASTDRIVER.EXE LADDRIVER.EXE LADC DRIVER.EXE
```

This installation has found drivers on your system that indicate that you are using either RSM or PATHWORKS. This installation will continue; however, the InfoServer client will not be able to start up if the PATHWORKS or RSM startup is executed before the InfoServer client startup.

```
%ESS-W-FILFND, The following control programs were found in SYS$SYSTEM.  
-ESS-W-FILFND, LASTCP.EXE
```

This installation has found versions of Control Programs that may not be compatible with the new drivers. New versions of the control programs will be provided by this installation. If these control programs were provided by either the RSM or PATHWORKS products, you will want to review Appendix C and the post-installation chapter of the installation guide that came with this kit detailing the ordering of startups for the InfoServer client, RSM and PATHWORKS server.

Installing InfoServer Client for OpenVMS

This chapter explains how to install InfoServer Client for OpenVMS. Section 3.1 contains a step-by-step description of the installation procedure.

3.1 Running the Installation Procedure

The InfoServer Client for OpenVMS installation procedure consists of a series of questions and informational messages. See Appendix B for a sample installation.

To abort the installation procedure at any time, press Ctrl/y. When you press Ctrl/y, the installation procedure deletes all files it has created up to that point and exits. You can then start the installation again.

To run the installation procedure, follow these steps:

- 1 Invoke VMSINSTAL.

```
@SYS$UPDATE:VMSINSTAL saveset-name device-name OPTIONS N
```

To start the installation, invoke the VMSINSTAL command procedure from a privileged account, such as the SYSTEM account. VMSINSTAL is in the SYS\$UPDATE directory. The following list defines the elements of the VMSINSTAL command procedure:

saveset-name

The installation name for the component. For InfoServer Client for OpenVMS, use the following installation name: **ESS022**

device-name

The name of the device on which you plan to mount the media. For example, MUA0: is the device name for a tape drive. It is not necessary to use the console drive for this installation. However, if you do use the console drive, you should replace any media you removed once the installation is complete.

Installing InfoServer Client for OpenVMS

3.1 Running the Installation Procedure

OPTIONS N

An optional parameter that indicates you want to see the question on release notes. If you do not include the `OPTIONS N` parameter, `VMSINSTAL` does not ask you about the release notes. You should review the release notes before proceeding with the installation in case they contain additional information about the installation. If you are restarting the installation and have already reviewed the release notes, you do not need to specify `OPTIONS N`.

Note that there are several other options you can select when you invoke `VMSINSTAL`:

- Auto-answer option (A): Initially creates a file that contains your answers to `VMSINSTAL` questions and prompts. You can then use the option (and the answer file) to save time during a reinstallation (typically after upgrading your system).
- Get save set option (G): Lets you store product save sets temporarily on a magnetic tape or in a disk directory.
- File log option (L): Logs all activity to the terminal during installation.
- Alternate root option (R): Lets you install the product to a system root other than that of the running system.

See the OpenVMS documentation on software installation in the OpenVMS System Management Subkit for detailed information on these options. If you specify more than one option, separate the options with commas (`OPTIONS A,N`).

The following example invokes `VMSINSTAL` to install InfoServer Client for OpenVMS from tape drive `MTA0:` and shows the system response. This example uses the `OPTIONS N` release note parameter.

\$

```
VAX/VMS Software Product Installation Procedure V5.4
```

```
It is 25-Mar-1992 at 15:00.  
Enter a question mark (?) at any time for help.
```

If you do not supply either the product name or the device name, `VMSINSTAL` prompts you for this information later in the installation procedure. `VMSINSTAL` does not prompt you for any options, so be sure to include `OPTIONS N` on the `VMSINSTAL` command line to access the release notes during the installation.

Installing InfoServer Client for OpenVMS

3.1 Running the Installation Procedure

2 Confirm DECnet status.

```
%VMSINSTAL-W-DECNET, Your DECnet network is up and running.
```

```
.  
.  
.
```

```
* Do you want to continue anyway [NO]?
```

VMSINSTAL notifies you if your DECnet network is running and displays a list of all active processes. It then asks if you want to continue the installation. You should install InfoServer Client for OpenVMS on a standalone system or cluster with DECnet shut down. NO is the default response to the question.

If you are installing on OpenVMS VAX Version 5.2 or higher, VMSINSTAL does not check the DECnet status. You can install InfoServer Client for OpenVMS while DECnet is up and running.

3 Confirm system backup.

```
* Are you satisfied with the backup of your system disk [YES]?
```

VMSINSTAL asks if you are satisfied with your system backup. You should always back up your system disk before performing an installation. If you are satisfied with the backup of your system disk, press the Return key. Otherwise, enter NO to discontinue the installation. After you back up your system disk, you can restart the installation.

4 Mount the media.

```
Please mount the first volume of the set on MUA0:.
```

```
* Are you ready?
```

```
%MOUNT-I-MOUNTED, ESS MOUNTED ON _$1$MUA0: (NODE1)
```

```
The following products is processed:
```

```
ESS V2.2
```

```
Beginning installation of ESS V2.2 at 20:01
```

```
%VMSINSTAL-I-RESTORE, Restoring product saveset A...
```

You should now mount the first distribution volume on the device you specified when you invoked VMSINSTAL. The device name appears in the line preceding the question. VMSINSTAL then asks you if you are ready to continue with the installation.

If you respond YES to indicate that you are ready, VMSINSTAL displays a message that the media containing InfoServer Client for OpenVMS has been mounted on the specified device and that the installation has begun.

Installing InfoServer Client for OpenVMS

3.1 Running the Installation Procedure

If you entered the wrong device name when you invoked VMSINSTAL and need to restart the installation, enter NO in response to the "Are you ready?" question. To abort the installation for other reasons, press Ctrl/y.

5 Mount additional media volumes.

```
%BACKUP-I-READYREAD, mount volume 2 on _MUA0: for reading
```

Enter "YES" when ready:

If your installation kit contains more than one volume, VMSINSTAL prompts you to mount the additional volumes and then asks you to indicate that you are ready for the installation to proceed.

6 Select a release notes option.

If you specified OPTIONS N when you started the installation, VMSINSTAL asks a question on release notes. There are four options available:

Release notes included with this kit are always copied to SYS\$HELP.

Additional Release Notes Options:

1. Display release notes
2. Print release notes
3. Both 1 and 2
4. None of the above

* Select option [2]:

If you select option 1, VMSINSTAL displays the release notes immediately on the console terminal. You can terminate the display at any time by pressing Ctrl/C.

If you select option 2, VMSINSTAL prompts you for the name of the print queue:

* Queue name [SYS\$PRINT]:

You can press the Return key to send the file to the default output print device or you can enter another queue name.

If you select option 3, VMSINSTAL displays the release notes immediately on the console terminal and then prompts you for a queue name for the printed version.

Select option 4 if you reviewed the release notes and are restarting the installation.

Installing InfoServer Client for OpenVMS

3.1 Running the Installation Procedure

Next, VMSINSTAL displays the following question:

```
* Do you want to continue the installation [N]?:  
%VMSINSTAL-I-REMOVED, The product's release notes have been  
successfully moved to SYS$HELP.
```

To continue the installation, enter YES. Otherwise, press the Return key. In either case, the release notes are copied to a file in the SYS\$HELP directory:

```
SYS$HELP:ESS022.RELEASE_NOTES
```

After the installation, you can enter the following command to review the release notes.

```
$
```

Note

The name of the release notes file installed by VMSINSTAL contains the current product name and version number. Do not delete release notes for previous versions of InfoServer Client for OpenVMS.

7 Purge files.

```
* Do you want to purge files replaced by this installation [YES]?
```

You have the option to purge files from previous versions of InfoServer Client for OpenVMS that are superseded by this installation. Purging is recommended; however, if you need to keep files from the previous version, enter NO in response to the question.

8 Choose the Installation Verification Procedure (IVP) option.

```
* Do you want to run the IVP after the installation [YES]?
```

The installation procedure now asks if you want to run the IVP. The IVP for InfoServer Client for OpenVMS checks to be sure that the installation is successful. For this field test release there is no IVP.

9 Choose System reboot option.

Under certain conditions, the installation procedure may require a reboot of your system. A message will be displayed and you will be asked if you want the installation procedure to perform the reboot for you. If you answer no the install will continue.

Installing InfoServer Client for OpenVMS

3.1 Running the Installation Procedure

W A R N I N G

This installation has detected that support for the InfoServer Tape Client for OpenVMS has never been installed on this system and that the LAST transport is running. Attempting to use the InfoServer Tape Client for OpenVMS will crash your system. If you want to use the Tape Client immediately, answer YES to the next question and allow this procedure to reboot your system.

To complete the installation of this product, you should reboot the system. If it is not convenient to reboot at this time, then enter NO to the following question.

If you enter NO, the installation procedure will continue.

* Will you allow a system shutdown after this product is installed [YES]?

10 Read informational messages.

At this point, the installation procedure displays a number of informational messages that report on the progress of the installation. There are no further questions. If the installation procedure has been successful up to this point, VMSINSTAL moves the new or modified files to their target directories, updates help files, and updates DCL tables, if necessary. If you chose to have files purged, that work is done now. The following messages are displayed:

```
%VMSINSTAL-I-MOVEFILES, files will now be moved to their target
                                directories...
```

11 Observe the Installation Verification Procedure (IVP).

If you chose to run the IVP, VMSINSTAL runs it now. When the IVP runs successfully, you see the following display:

Installing InfoServer Client for OpenVMS

3.1 Running the Installation Procedure

Starting IVP for DEC InfoServer Client for OpenVMS V2.2 .

```
%LAST-I-RUNNING, is already running
%LASTTCP-I-VERSION, LASTDRIVER X1.5 is running
```

The DEC InfoServer Client for OpenVMS V2.2 IVP has successfully started LASTport.

The DEC InfoServer Client for OpenVMS V2.2 IVP has successfully loaded the disk client.

The DEC InfoServer Client for OpenVMS V2.2 IVP has successfully loaded the tape client.

IVP for DEC InfoServer Client for OpenVMS V2.2 completed.

12 End the installation procedure.

Installation of ESS V2.2 completed at 15:14

VMSINSTAL procedure done at 15:16

The previous messages indicate that the entire installation procedure is complete.

You can now log out of the privileged account:

```
$
SYSTEM    logged out at 25-Mar-1992 15:20:03.78
```

Note that VMSINSTAL deletes or changes entries in the process symbol tables during the installation. Therefore, if you are going to continue using the system manager's account and you want to restore these symbols, you should log out and log in again.

3.2 Error Recovery

If errors occur during the installation itself or when the Installation Verification Procedure (IVP) is running, VMSINSTAL displays failure messages. If the installation fails, you see the following message:

```
%VMSINSTAL-E-INSFAIL, The installation of ESS V2.2 has failed.
```

Errors can occur during the installation if any of the following conditions exist:

- The operating system version is incorrect.
- A prerequisite software version is incorrect.
- Quotas necessary for successful installation are insufficient.

Installing InfoServer Client for OpenVMS

3.2 Error Recovery

- System parameter values for successful installation are insufficient.
- The OpenVMS help library is currently in use.
- The product license has not been registered and loaded.

For descriptions of the error messages generated by these conditions, see the OpenVMS documentation on system messages, recovery procedures, and OpenVMS software installation. If you are notified that any of these conditions exist, you should take the appropriate action as described in the message. For information on installation requirements, see Chapter 2.

After Installing InfoServer Client for OpenVMS

You perform the following tasks after installing InfoServer Client for OpenVMS:

- Optionally run the Installation Verification Procedure separately
- Edit the system startup and shutdown files
- Make the product usable on a VAXcluster system
- Set user account quotas
- Report problems

4.1 Running the Installation Verification Procedure Separately

To run the IVP after the installation has completed, enter the following command from a suitably privileged account.

```
$
```

4.2 Editing the System Files

You must edit the system startup files to provide for automatic startup and shutdown of InfoServer Client for OpenVMS when your system is rebooted.

Add the command line that starts InfoServer Client for OpenVMS to the system startup file, SYS\$MANAGER:SYSTARTUP_V5.COM. You must position this new command line after) the line that invokes the DECnet network startup command procedure. The following example shows the network startup command line followed by the InfoServer Client for OpenVMS startup command line:

After Installing InfoServer Client for OpenVMS

4.2 Editing the System Files

```
$
```

```
.  
.  
.
```

```
$
```

4.2.1 Startup Restrictions: PCSA and RSM

If PCSA or RSM or both are installed, the InfoServer Client for OpenVMS startup must be run before the startup for PCSA or RSM or both.

```
$
```

```
.  
.  
.
```

```
$
```

```
$
```

```
$
```

The InfoServer Client for OpenVMS provides device drivers and control programs that are shared by both the PCSA and RSM products. All of the components of the InfoServer Client for OpenVMS are prefixed with ESS\$. The drivers and control programs provided in the InfoServer Client for OpenVMS provide all necessary support for both PCSA and RSM in addition to InfoServer Client support. It is necessary that the InfoServer Client for OpenVMS startup be executed in the site-specific startup before either the PCSA or RSM startup procedures.

4.2.2 Startup Restrictions: SYSMAN

The startup for InfoServer Client for OpenVMS from a subprocess will fail. Because the OpenVMS System Management Utility (SYSMAN) uses subprocesses to complete its tasks on remote nodes, SYSMAN cannot be used to execute the SYS\$STARTUP:ESS\$STARTUP procedure.

4.3 User Account Requirements

To work with InfoServer Client for OpenVMS, user accounts on your system must have certain privileges and quotas. The next two sections contain information on these requirements.

4.3.1 Privileges

To use InfoServer Client for OpenVMS, GRPNAM privilege is required if the /GROUP qualifier of the LAD Control Program (LADCP) BIND command used and SYSNAM privilege is required if the /SYSTEM qualifier of the LADCP BIND command is specified.

4.3.2 User Account Quotas

To use InfoServer Client for OpenVMS, the UAF account quotas that are in the DEFAULT UAF record are the minimum values.

See Section 2.4.2 for a description of how to verify and change account quotas.

4.4 Determining and Reporting Problems

If you encounter a problem while using InfoServer Client for OpenVMS, report it to Digital. Depending on the nature of the problem and the type of support you have, you can take one of the following actions:

- Call Digital if your software contract or warranty agreement entitles you to telephone support.
- Submit a Software Performance Report (SPR).
- Fill out and submit a Reader's Comments form if the problem has to do with the InfoServer Client for OpenVMS documentation. There are Reader's Comments forms at the back of each manual. Use the form from the manual in which you found the error. Include the section and page number.

Review the Software Product Description (SPD) and Warranty Addendum for an explanation of warranty. If you encounter a problem during the warranty period, report the problem as indicated above or follow alternate instructions provided by Digital for reporting SPD nonconformance problems.

A

Files and Logical Names Installed on Your System

The InfoServer Client for OpenVMS installation procedure installs a number of files on your system and defines some logical names. Section A.1 lists the files installed. Section A.2 lists the logical names that are added to the system logical name table.

A.1 File Names

The following list contains the names of all files created on your system when InfoServer Client for OpenVMS is installed if your system is running OpenVMS VAX Version 5.4 or higher.

- SYS\$HELP:ESS\$LADCP.HLB
- SYS\$HELP:ESS\$LASTCPHELP.HLB
- SYS\$HELP:[EXAMPLES]ESS\$RSM\$SERVER_STARTUP.COM
- SYS\$HELP:ESS022.RELEASE_NOTES
- SYS\$LOADABLE_IMAGES:ESS\$LADDRIVER.EXE
- SYS\$LOADABLE_IMAGES:ESS\$DADDRIVER.EXE
- SYS\$LOADABLE_IMAGES:ESS\$MADDRIVER.EXE
- SYS\$LOADABLE_IMAGES:ESS\$LADCDRIVER.EXE
- SYS\$LOADABLE_IMAGES:ESS\$LASTDRIVER.EXE
- SYS\$MANAGER:ESS\$MOUNT.TEMPLATE
- SYS\$STARTUP:ESS\$STARTUP.COM
- SYS\$STARTUP:ESS\$LAD_STARTUP.COM
- SYS\$STARTUP:ESS\$LAD_STARTUP.DAT
- SYS\$STARTUP:ESS\$LAST_STARTUP.COM

Files and Logical Names Installed on Your System

A.1 File Names

- SYS\$STARTUP:ESS\$LAST_STARTUP.DAT
- SYS\$SYSTEM:ESS\$LASTCP.EXE
- SYS\$SYSTEM:ESS\$LADCP.EXE
- SYS\$TEST:ESS022.DIR
- SYS\$TEST:ESS022_IVP.COM

The following additional files are added to your system when InfoServer Client for OpenVMS is installed if your system is running OpenVMS VAX Version 5.0 through 5.3-n.

- SYS\$LIBRARY:MOUNTSHR.EXE
- SYS\$UPDATE:ESS\$CLUSTER_INSTALL_MOUNT.COM

A.2 Logical Names

InfoServer Client for OpenVMS creates logical names in the appropriate table whenever the LADCP bind command is executed. In order to place logical names in any table other than the process table, the appropriate privileges are required. See Section 4.3.1 for the specific requirements.

Creating a logical in the process table:

```
$
LADCP>
%LADCP-I-BIND, service bound to logical unit MAD$TAPE_1 (_MAD20:)
LADCP>
$
  "MAD$TAPE_1" [super] = "_MAD20:" [concealed] (LNM$PROCESS_TABLE)
```

Creating a logical in the group table:

```
$
LADCP>
%LADCP-I-BIND, service bound to logical unit MAD$TAPE_1 (_MAD21:)
LADCP>
$
  "MAD$TAPE_1" [super] = "_MAD21:" [concealed] (LNM$GROUP_000104)
```

Creating a logical in the system table:

```
$
LADCP>
%LADCP-I-BIND, service bound to logical unit MAD$TAPE_1 (_MAD22:)
LADCP>
$
  "MAD$TAPE_1" [exec] = "_MAD22:" [concealed] (LNM$SYSTEM_TABLE)
```

Sample Installation: Run-Time Kit

This appendix contains a sample installation of InfoServer Client for OpenVMS. This sample was run on a system that had no previous version of InfoServer Client for OpenVMS installed. Depending on which layered products you have on your system, you might see additional messages and questions when you perform your installation.

The sample installation assumes that your DECnet network is up, that no users are logged in to your system, and that OPTIONS N is specified to print the release notes.

Username:

Password:

```
Welcome to VAX/VMS Version 5.5 on node NODE1
  Last interactive login on Wednesday, 25-SEP-1992 10:08
  Last non-interactive login on Tuesday, 25-SEP-1992 9:03
```

\$

```
VAX/VMS Software Product Installation Procedure V5.4
```

It is 25-SEP-1992 at 10:10.

Enter a question mark (?) at any time for help.

* Are you satisfied with the backup of your system disk [YES]?

The following products is processed:

ESS V2.2

Beginning installation of ESS V2.2 at 10:11

Please mount the first volume of the set on MUA0:.

* Are you ready?

%MOUNT-I-MOUNTED, ESS mounted on _MUA0:

%VMSINSTAL-I-RESTORE, Restoring product saveset A ...

%VMSINSTAL-I-REMOVED, Product's release notes have been moved to SYS\$HELP.

Sample Installation: Run-Time Kit

- * Do you want to run the IVP after the installation [YES]?
- * Do you want to purge files replaced by this installation [YES]?

W A R N I N G

This installation has detected that support for the InfoServer Tape Client for OpenVMS has never been installed on this system and that the LAST transport is running. Attempting to use the InfoServer Tape Client for OpenVMS will crash your system. If you want to use the Tape Client immediately, answer YES to the next question and allow this procedure to reboot your system.

To complete the installation of this product, you should reboot the system. If it is not convenient to reboot at this time, then enter NO to the following question.

If you enter NO, the installation procedure will continue.

- * Will you allow a system shutdown after this product is installed [YES]?
- %ESS-I-CONTINUE, No more questions will be asked.
%ESS-I-MOVFIL, Providing IVP SY\$TEST:ESS022_IVP.COM
%VMSINSTAL-I-SYSDIR, This product creates system directory [SY\$TEST.ESS022].

If you intend to execute this layered product on other nodes in your VAXcluster, and you have the appropriate software license, you must prepare the system-specific roots on the other nodes by issuing the following command on each node (using a suitably privileged account):

```
$ CREATE /DIRECTORY SY$SPECIFIC:[SY$TEST.ESS022]
%ESS-I-MOVFIL, Providing startup and configuration files.
%ESS-I-MOVFIL, Providing help files.
%ESS-I-LINK, Linking drivers and control programs.
%ESS-I-MOVFIL, Providing control programs.
%ESS-I-MOVFIL, Providing drivers.
```

After this installation completes, be sure to edit SY\$STARTUP_V5.COM to invoke

```
$@SY$STARTUP:ESS$STARTUP tape disk
```

to start the protocols. If this is executed before DECnet is started with STARTNET.COM, then the SY\$GEN parameter SC\$SYSTEMID must be set up correctly to allow DECnet to start normally. If this parameter is zero, then execute ESS\$STARTUP after STARTNET. If you do not start DECnet be sure that the SY\$GEN parameter SC\$NODE is non-blank or the LAST transport will not be able to start.

You may also want to execute ESS\$STARTUP when the kit installation completes to be able to access the network CD-ROMs without rebooting.

Another command procedure template is provided:

Sample Installation: Run-Time Kit

```
SYS$MANAGER:ESS$MOUNT.TEMPLATE
```

This file contains sample commands necessary to make the CD-ROMs available as local disks. Use this as a guide to create the command file:

```
SYS$MANAGER:ESS$MOUNT.COM
```

You may then execute the procedure at the end of the installation to make use of the network CD-ROMs. After this installation completes, be sure to edit SYSTARTUP_V5.COM to invoke

```
$@SYS$MANAGER:ESS$MOUNT.COM
```

If this system has RSM or PCSA or both installed, be sure to read the Install Guide that came with this product for IMPORTANT startup ordering information. If you install either PCSA or RSM after this kit has been installed, it may be necessary to re-install this kit. See the Install Guide for this product for specific information.

Continuing installation...

```
%VMSINSTAL-I-MOVEFILES, Files will now be moved to their target directories...
```

```
Starting IVP for InfoServer Client for OpenVMS V2.2 .
```

```
%LAST-I-RUNNING, is already running
```

```
%LASTTCP-I-VERSION, LASTDRIVER X1.5 is running
```

```
The InfoServer Client for OpenVMS V2.2 IVP has successfully started LAST.
```

```
The InfoServer Client for OpenVMS V2.2 IVP has successfully loaded the disk client.
```

```
The InfoServer Client for OpenVMS V2.2 IVP has successfully loaded the tape client.
```

```
IVP for InfoServer Client for OpenVMS V2.2 completed.
```

```
Installation of ESS V2.2 completed at 10:16
```

```
Enter the products to be processed from the next distribution volume set.
```

```
* Products:
```

```
VMSINSTAL procedure done at 10:17
```

Sample Installation: Run-Time Kit

```
$  
SYSTEM      logged out at 25-SEP-1992 10:17:18.01
```

Index

C

Compact disc
formats for automatic serving, 1-1
Conventions, vi

D

Downline loading, 1-2

F

Files created, A-1

I

InfoServer Client for OpenVMS
components, 1-3
functions, 1-3
InfoServer system
functions, 1-1
overview, 1-1
relationship to client systems, 1-2
virtual device server, 1-1
Installation
Account quotas, 2-3
Backing up system disk, 2-5
disk space required, 2-2
license registration not required, 2-2
preparing for, 2-1
privileges required, 2-2
required software, 2-1
sample session, B-1
VMSINSTAL requirements, 2-4

L

Logical names created, A-1

O

OpenVMS
and downline loading, 1-2

P

Partition, 1-2
PATHWORKS
check before starting InfoServer Client for
OpenVMS, 2-5

R

Read/write disk
partitions, 1-2
RSM
check before starting InfoServer Client for
OpenVMS, 2-5

S

System disk
backing up, 2-5

V

VAX systems

downline loading, 1-2

How to Order Additional Documentation

Technical Support

If you need help deciding which documentation best meets your needs, call 800-343-4040 before placing your electronic, telephone, or direct mail order.

Electronic Orders

To place an order at the Electronic Store, dial 800-DEC-DEMO (800-332-3366) using a 1200- or 2400-baud modem. If you need assistance using the Electronic Store, call 800-DIGITAL (800-344-4825).

Telephone and Direct Mail Orders

Your Location	Call	Contact
Continental USA, Alaska, or Hawaii	800-DIGITAL	Digital Equipment Corporation P.O. Box CS2008 Nashua, New Hampshire 03061
Puerto Rico	809-754-7575	Local Digital subsidiary
Canada	800-267-6215	Digital Equipment of Canada Attn: DECdirect Operations KAO2/2 P.O. Box 13000 100 Herzberg Road Kanata, Ontario, Canada K2K 2A6
International	—————	Local Digital subsidiary or approved distributor
Internal ¹	—————	USASSB Order Processing - WMO/E15 <i>or</i> U.S. Area Software Supply Business Digital Equipment Corporation Westminster, Massachusetts 01473

¹For internal orders, you must submit an Internal Software Order Form (EN-01740-07).

Reader's Comments

InfoServer Client for OpenVMS
Installation Guide

AA-PF4DB-TE

Please use this postage-paid form to comment on this manual. If you require a written reply to a software problem and are eligible to receive one under Software Performance Report (SPR) service, submit your comments on an SPR form.

Thank you for your assistance.

I rate this manual's:	Excellent	Good	Fair	Poor
Accuracy (software works as manual says)	<input type="checkbox"/>	<input type="checkbox"/>	<input type="checkbox"/>	<input type="checkbox"/>
Completeness (enough information)	<input type="checkbox"/>	<input type="checkbox"/>	<input type="checkbox"/>	<input type="checkbox"/>
Clarity (easy to understand)	<input type="checkbox"/>	<input type="checkbox"/>	<input type="checkbox"/>	<input type="checkbox"/>
Organization (structure of subject matter)	<input type="checkbox"/>	<input type="checkbox"/>	<input type="checkbox"/>	<input type="checkbox"/>
Figures (useful)	<input type="checkbox"/>	<input type="checkbox"/>	<input type="checkbox"/>	<input type="checkbox"/>
Examples (useful)	<input type="checkbox"/>	<input type="checkbox"/>	<input type="checkbox"/>	<input type="checkbox"/>
Index (ability to find topic)	<input type="checkbox"/>	<input type="checkbox"/>	<input type="checkbox"/>	<input type="checkbox"/>
Page layout (easy to find information)	<input type="checkbox"/>	<input type="checkbox"/>	<input type="checkbox"/>	<input type="checkbox"/>

I would like to see more/less _____

What I like best about this manual is _____

What I like least about this manual is _____

I found the following errors in this manual:

Page	Description
_____	_____
_____	_____
_____	_____

Additional comments or suggestions to improve this manual:

I am using **Version** _____ of the software this manual describes.

Name/Title _____ Dept. _____

Company _____ Date _____

Mailing Address _____

_____ Phone _____

Do Not Tear - Fold Here and Tape



DIGITAL EQUIPMENT CORPORATION
Corporate User Information Products
ZKO1-3/J35
110 SPIT BROOK RD
NASHUA, NH 03062-9987



Do Not Tear - Fold Here

digital