

**OSBORNE COMPUTER CORPORATION  
OCC-1/EXECUTIVE COMPUTER  
DIAGNOSTIC PROCEDURES**

**SBXNED010**

Prepared by:  
Xerox Corporation  
Xerox Service Business  
Service Education & Customer Support  
1341 W. Mockingbird Lane  
Dallas, Texas 75247

JANUARY 1984



## TABLE OF CONTENTS

|  | PAGE |
|--|------|
| OCC DIAGNOSTIC DOCUMENT PURPOSE                      | 3    |
| DIAGNOSTIC MATERIALS REQUIRED                        | 3    |
| <u>OCC-1 DIAGNOSTIC DISKETTE INFORMATION</u>         |      |
| INTRODUCTION   | 4    |
| LOOPBACK PLUGS                                       | 6    |
| DISK DRIVE TESTS                                     | 6    |
| MEMORY TESTS   | 7    |
| SERIAL PORT TEST                                     | 7    |
| PARALLEL PORT TEST                                   | 8    |
| ROM TEST   | 10   |
| DRIVE EXERCISER                                      | 10   |
| SEEK TRACK   | 11   |
| DRIVE TIMER  | 11   |
| HOME HEAD  | 11   |
| ALTERNATE TRACK                                      | 11   |
| DISK DRIVE STEP RATE                                 | 11   |
| TEST PATTERN   | 11   |
| ERROR SUMMARIES                                      | 12   |
| CLEAR ERROR TOTALS                                   | 12   |
| CP/M FILES   | 13   |
| COPY   | 13   |
| VIDEO TEST PATTERN                                   | 13   |
| SPEED TEST   | 13   |
| SYSGEN   | 14   |
| SETUP  | 14   |
| PIP  | 15   |
| KEYBOARD TEST  | 15   |
| <u>OCC-EXECUTIVE DIAGNOSTIC DISKETTE INFORMATION</u> |      |
| INTRODUCTION   | 18   |
| CP/M FILES LISTING                                   | 18   |
| COMPLEXITY SELECTIONS                                | 19   |
| TEST CONFIGURATIONS                                  | 20   |
| LOOPBACK PLUGS                                       | 21   |
| COMMAND MENU   | 22   |
| COMMANDS   | 24   |
| DISK DRIVE ERROR REPORTS                             | 27   |
| LOGIC BOARD TESTS                                    | 31   |
| MEMORY BOARD TESTS                                   | 32   |
| DISK DRIVE TESTS                                     | 32   |
| TEST PATTERNS  | 34   |
| KEYBOARD TEST  | 35   |
| MBASIC   | 35   |
| SHOW FILE  | 36   |
| PIP  | 36   |
| SINE FILE  | 36   |
| COPYSYS  | 37   |
| COPY   | 38   |
| FORMAT   | 38   |
| SDDBIT (DRIVE ERROR RATE TEST)                       | 38   |
| SPEED TEST   | 39   |
| CONTEST FILE   | 40   |
| SETUP  | 41   |



## OCC DIAGNOSTICS

### PURPOSE

The purpose of this manual is to state the diagnostic procedures available for use in troubleshooting the Osborne 1 and Executive Computers. The procedures included will explain the use of the OCC-1 Diagnostic Diskette and the Field Service Department Executive Diagnostic diskette.

Through the use of these diagnostics the Logic Board, Memory Board (Executive only), Floppy Diskette Drives, Screen, and Keyboard can be verified or aligned.

This manual will also explain the procedures required to load and use the available CP/M files to assist you in troubleshooting and verifying correct operation of the Osborne Computers.

This manual is divided into two sections. The first, OCC EXECUTIVE DIAGNOSTIC PROCEDURES, explains step-by-step how to use the diagnostics and CP/M files on the diskette. The second section is a description of the step-by-step procedures to use the OCC 1 Diagnostic Diskette.

### MATERIALS REQUIRED

The Osborne Field Service Department Executive Diagnostic Diskette and the OCC-1 Diagnostic Diskette are the primary sources of diagnostic and utility programs used to troubleshoot the Osborne Computers.

To run all available diagnostic tests the following items will be required:

|   |                                      |
|---|--------------------------------------|
| <b>Osborne OCC-1 Diagnostic Diskette</b>                              | <b>Xerox part no. TO BE SUPPLIED</b> |
| <b>Osborne Field Service Department Executive Diagnostic Diskette</b> | <b>Xerox part no. TO BE SUPPLIED</b> |
| <b>2 5¼" single-sided floppy diskettes</b>                            |                                      |
| <b>1 RS-232C "loopback plug" (Executive)</b>                          | <b>Xerox part no. TO BE SUPPLIED</b> |
| <b>1 IEEE 488 "loopback plug" (Executive)</b>                         | <b>Xerox part no. TO BE SUPPLIED</b> |
| <b>1 RS232 "loopback plug" (OCC-1)</b>                                | <b>Xerox part no. TO BE SUPPLIED</b> |
| <b>1 IEEE-488 "loopback plug" (OCC-1)</b>                             | <b>Xerox part no. TO BE SUPPLIED</b> |



## OCC-1 DIAGNOSTIC DISKETTE

### INTRODUCTION

The Osborne OCC-1 Field Service System Confidence Test Diagnostic Diskette is a menu driven diagnostic software package for Service Center Technician use in troubleshooting and verifying correct operation of the Osborne OCC-1 Computer. The Diagnostic Diskette contains tests which are capable of exercising the following components:

- Logic PWB
- Floppy Diskette Drives
- Keyboard

The OCC-1 Field Service System Confidence Test Diagnostic Diskette also has the capability of displaying various CRT test patterns to assist you in aligning the video presentation.

The following files are also located on the Field Service System Confidence Test Diagnostic Diskette:

- COPY (Copy or format diskettes)
- VIDEO (Test pattern display)
- SPEED (Diskette drive timer)
- SYSGEN (Operating System Generation Program)
- SETUP (Configuration program)
- PIP (Peripheral Interchange Program)
- KB (KeyBoard Test)

The OCC-1 Diagnostic Diskette is not designed as a "chip level" troubleshooting tool (although some tests will define to the chip level). To expedite repair the diagnostic will display a failure, when it occurs, to one of the field replaceable units (Logic PWB, Floppy Disk Drive, or Keyboard).

# OCC-1 DIAGNOSTIC DISKETTE

## PROCEDURES

Press the Power On/Off button to apply power to the OCC-1 Computer.

When the screen displays "Insert disk in Drive A and press RETURN.\_\_" insert the OCC-1 Field Service System Confidence Test Diagnostic Diskette into the left drive (Drive A) and press the RETURN key.

When the diskette has loaded the following will be displayed on the screen:

### FIELD SERVICE SYSTEM CONFIDENCE TEST 2.04 OCC1

O = cOnfidence test

#### MEMORY

A = refresh  
B = galpat  
C = v-bar  
D = diagonal  
E = run all memory test  
F = alter refresh delay

#### DRIVE

G = drive A  
H = drive B  
I = drives A & B

#### PORT

J = serial  
K = parallel

#### MISCELLANEOUS

L = rom test  
M = display sector  
N =  
P = DRIVE EXER  
Q = step rate  
R =  
S = screen pattern

#### ERROR SUMMARIES

T = print disk errors, serial  
U = print disk errors, parallel  
V = display disk errors hard  
W = display disk errors soft  
X = display memory  
  
Y = clear error totals  
Z = exit

INPUT LETTER COMMAND: \_\_

These are the available Confidence tests which can be used for assistance in troubleshooting the OCC-1 Computer. The tests are started by inputting the letter which is listed before the name of the test or function. The entries are divided into seven specific sections.

Now that the program is loaded into memory, remove the OCC-1 Field Service System Confidence Test Diagnostic Diskette from the left drive and insert blank diskettes (without the write-protect tapes) into drive A and drive B.



## OCC-1 DIAGNOSTIC DISKETTE

The Serial and Parallel Port test will require the use of loopback plugs. The plugs appear similar to the following diagrams:

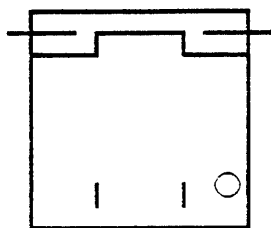

**SERIAL  
LOOPBACK PLUG**

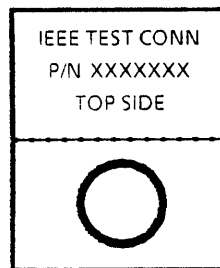

**PARALLEL  
LOOPBACK PLUG**

The Serial Loopback Plug should be inserted into the plug on the front bezel labeled "SERIAL RS232". The Parallel Loopback Plug is inserted into the plug on the front bezel marked "IEEE-488" with the side marked "TOP SIDE" facing up. Without these plugs installed the port tests will fail. The plugs turn the outgoing signals back into the logic board where they can be checked.

The first section of the test options is "0" the Confidence Test. This test is a combination of tests A, B, C, D, G, H, J, and K. It is a rather lengthy test (approximately 40 minutes) which is run in cycles. Not all tests are performed in each cycle. The initial part of the test is menu-driven although the test runs automatically. To start test "0" press the **O** key.

The screen will display the following:

### **SELECT DRIVE TEST DENSITIES**

**S** = Single Density Test Only  
**D** = Double Density Test Only  
**B** = Both Single and Double Density test

**INPUT LETTER COMMAND: \_\_**

If you want to test the disk drives in single density only you would type **S**; double density only you would type **D**; to test single and double density type **B** (select D or B only if the system has the Double Density option installed or errors will occur). When you enter your option the screen will respond with selections for the types of tests you can run.

## OCC-1 DIAGNOSTIC DISKETTE

Entering the letter **P** (pre-test) will cause the tests to be performed twice. If you enter the letter **F** (final-test) the test will be performed five times. If you type the letter **L** (loop-test) the tests will run twenty-five times. When you input the letter of the test type you want to run, the test will start and a new screen will be displayed.

The top line of the screen will indicate whether you are running a single density, double density, or both test. "**TEST CYCLE**" is the number of times the test has completed running.

The next line indicates "**HARD ERROR TOTALS ARE:**" Below the word "ARE" the number of hard (unrecoverable) errors will be listed corresponding to each of the test names (MEMORY, PARALLEL PORT, SERIAL PORT, DRIVE A, DRIVE B).

If an error occurs during the diskette drive test the words "**REJECT**" or "**POSSIBLE REJECT**" will be displayed on the screen. This depends upon the number of errors which occurred during the test. This informs you that the disk drive or diskette itself is not performing as expected.

The bottom line of the screen displays the currently running test on the left side, and the memory location, in hexadecimal if a memory test is being run, on the right side of the screen. If a diskette test is running, the current track which is under test will be displayed on the right side of the screen.

There are four sub-tests which are run during the "0" test under the heading of memory. They are "**REFRESH, GALPAT** (Gallop Pattern), **V-BAR**, and **MOVING DIAGONAL**". Each of these test various functions of the memory locations on the Logic Board. All of these tests are not run in every cycle. The Moving Diagonal test is run in the second cycle of the test (this test may take approximately 20 minutes to run). These tests can also be run independently from the "main menu" by selecting tests **A, B, C, or D**.

When the Memory Tests complete the "**SERIAL PORT**" test is performed. This tests the operation of the "**SERIAL RS232**" Port and the control circuits on the Logic Board. The loopback plug must be installed to loop the test signals back into the Logic Board for verification. If the plug is not installed the test will fail.

## OCC-1 DIAGNOSTIC DISKETTE

The next test to be run is the "**PARALLEL PORT**" test. This tests verifies the operation of the IEEE-488 Parallel Port and the control circuits on the Logic Board. The loopback plug must be installed to loop the test signals back into the Logic Board for verification. If the plug is not installed the test will fail.

The diskette drives are tested next. Both drives are exercised with the same testing procedures.

The first test is "**FORMAT / READ**". In this test all tracks of the diskette in drive A are formatted and then all of tracks of the diskette in drive B are formatted. If these tests passed with no errors, "**ONE CYCLE PASSED**" will be displayed on the screen and the next cycle will start. If errors occurred they will also be displayed. "**REJECT**" may be displayed on the screen if too many diskette errors are encountered. Every time a hard error occurs the number to the right of the drive name will update to show you the count. The columns to the right of the screen (NUMB, cyc#) indicate in what test and cycle number the failures occurred. The screen will update whenever an error is found.

The next cycle starts again with the memory **REFRESH** test. This is followed by the **GALPAT** and **V-BAR** memory test. The **SERIAL PORT** and **PARALLEL PORT** tests are again run. The diskette in drive A is then formatted again. The following diskette drive tests are then run in the sequence listed:

**HEAD MOVEMENT**  
**ALTERNATE SEEK**  
**SEEK/WRITE/READ/VERIFY**  
**SEEK/READ/VERIFY**

The diskette in drive B is then formatted and the same four tests are run.

The memory sequence of tests starts over again but this time the **MOVING DIAGONAL** test is also run (this test may take approximately 20 minutes to complete).

When the memory tests have run the diskette drive tests again start. The diskette in drive A is once again formatted. The following drive tests are then run:

## OCC-1 DIAGNOSTIC DISKETTE

**HEAD MOVEMENT TEST  
ALTERNATE SEEK TEST  
RANDOM SEEK TEST  
SEEK/WRITE/READ/VERIFY  
SEEK/READ/VERIFY  
ACCORDION/SEEK/WRITE/READ/VERIFY  
SEEK/READ/VERIFY  
RANDOM SEEK/WRITE/READ/VERIFY  
SEEK/READ/VERIFY  
ACCORDION/SEEK/READ/VERIFY  
RANDOM SEEK/READ/VERIFY**

When these tests completely run the diskette in drive B is formatted and the eleven tests run for drive A are repeated for drive B.

The HEAD MOVEMENT TEST rapidly moves the head to various tracks of the diskette in succession.

ALTERNATE SEEK tests move the head from one track to another and back continuously.

The SEEK/WRITE/READ/VERIFY test first seeks to a specific track. Data is written on that track, read, and verified.

ACCORDION tests start at track 0 and then test to track 39; track 1 to 38; track 2 to 37 and so on. When the middle of the diskette is reached the process starts in the reverse order working out towards tracks 0 and 39.

RANDOM tests occur on various tracks throughout the diskette surface.

Each of these tests is designed to exercise the control circuits and mechanisms of the diskette drive to its fullest. The Confidence test can be stopped at any time by pressing and holding the **CTRL** key and then pressing the **C** key. This action will return you to the main menu.

The main menu contains other tests and options for your use. Under the heading of **MEMORY** is selection **E**. By inputting this selection you are allowed to run all of the memory tests at one time.

## OCC-1 DIAGNOSTIC DISKETTE

Selection **F** (alter refresh delay) can be used to change the way in which the REFRESH MEMORY test is run. When **F** is entered the screen will display eight different delay times which you can set to change the rate at which the REFRESH TEST will run. By pressing the letter of the new refresh time you want to use the rate is changed. When the REFRESH TEST is run the test will pause for the length of time you specified before restarting each section of the test.

The **MISCELLANEOUS** section of the screen contains tests and other options which can be used. Selection **L** is the **ROM TEST**. When **L** is input the screen will display the following:

**(L) rom crc test**

**0 ROM REV: X.X CRC: XXXX**

CRC is an abbreviation for Cyclic Redundancy Check. This is a mathematical formula which is used to verify the data within the ROM. The second line lists the revision level of the ROM and a CRC number (the CRC number is of no value to us).

Selection **M**, **DISPLAY SECTOR**, is only used for software troubleshooting and analysis purposes.

**P** is the **DRIVE EXERCISER**. When this letter is entered the following will be displayed on the screen:

|                            |                             |                            |                              |                               |
|----------------------------|-----------------------------|----------------------------|------------------------------|-------------------------------|
| <u>HOME</u><br><u>HEAD</u> | <u>SEEK</u><br><u>TRACK</u> | <u>ALT</u><br><u>TRACK</u> | <u>DRIVE</u><br><u>TIMER</u> | <u>DRIVE</u><br><u>SELECT</u> |
| <hr/>                      |                             |                            |                              |                               |
| 0                          | 10                          | 20                         | 30                           |                               |

The numbers below the blocks indicate tracks.

The **DRIVE SELECT** block is used to select the drive you wish to use (A or B). The **RETURN** key does not have to be pressed.

## OCC-1 DIAGNOSTIC DISKETTE

Use the arrow key to highlight the **SEEK TRACK** block. When the RETURN key is pressed the screen will respond with "**Enter new track number (0-39)**". Enter the number and when the RETURN key is pressed the drive will seek to the location you input. The indicator on the line of the screen will be placed at the selected track also.

The **DRIVE TIMER** is used to monitor the speed of the drive to verify correct speed and adjust if necessary. To run the DRIVE TIMER correctly a seek to track 16 should be performed first. With the head at track 16 use the arrow key to highlight the DRIVE TIMER block. When the RETURN key is pressed the speed in milliseconds is displayed in a box on the center of the screen. The correct speed for the ALPS drive in the Executive Computer is  $200 \pm 1$  milliseconds (VR1 on the spindle-motor control board should be adjusted to obtain this setting).

The **HOME HEAD** selection is used to move the head back to the home position. Use the arrow key to highlight the HOME HEAD block. When the RETURN key is pressed the head will move to home from its location. The indicator on the line of the screen will also indicate the home position.

The **ALT TRACK** selection is used to cycle the head from one track to another. Use the arrow keys to select the ALT TRACK block and press the RETURN key. The screen will respond with "**Enter new track number (0-39):**" When you enter the new number and press the RETURN key the head will alternate from the current track to the track you input. To change the current track use the SEEK TRACK block and then return to the ALT HEAD block.

Press and hold the CTRL key and press the C key to exit this test to return to the main menu.

**Q** is used to change the **STEP RATE** for the diskette drive tests. When this key is entered a list of times is displayed. Notice the times are in milliseconds. When the STEP RATE (rate at which the head will change track positions) is changed you probably won't see much difference because of the short time frames involved.

When you enter selection **S** a test pattern will be displayed on the CRT. This pattern can be used for alignment. Refer to the Osborne Field Service Manual for alignment of the 5" CRT.

## OCC-1 DIAGNOSTIC DISKETTE

By pressing the RETURN key the main menu will again be displayed.

The **ERROR SUMMARIES** section of the screen is used to print or display the errors that we encountered while running the tests. Selections **T** and **U** can be used to print the summary if a printer is connected to the Serial or Parallel ports. When **V** is pressed the diskette **HARD** (unrecoverable) **ERRORS** will be displayed. The screen lists the **HARD ERROR TOTALS**, the **NUMB** (number of times in each test an error occurred), and the **cyc#** (the cycle number in which the error occurred).

Press the RETURN key to display the main menu. The **W** entry will display the soft (recoverable) errors encountered while testing. The screen displays the **SOFT ERROR TOTALS**, the **NUMB** (number of times in each test an error occurred), and the **cyc#** (the cycle number in which the error occurred). When you press and hold the **CTRL** key and then press the left arrow key, the screen will scroll to the left and display the error for diskette drive A. Press the RETURN key and you will display the main menu.

The **X** selection displays information on the memory test. When **X** is pressed the screen lists the four **MEMORY TEST**, the number of **CYCLES** run, and the number of **ERRORS** which occurred. The data towards the bottom of the screen lists the locations of the RAM chips on the Logic Board. If a location had an error a 1 would be placed at the coordinates. The RAM chips are located at positions 20 - 27 in Rows A, B, C, and D. Press the RETURN key to again display the main menu.

The **Y** entry is used to **CLEAR** the **ERROR TOTALS**. This will erase all previous information on error logging. The accumulated entries will start from 0.

The last selection on the screen is **Z**. It is used to exit the Confidence tests and display the operating system files. Remove the blank diskette from drive A and insert the OCC-1 Field Service System Confidence Test Diagnostic Diskette into the left drive (Drive A). Press the **Z** key. The diskette will be accessed and load the operating system software into memory. When it is loaded the CP/M prompt (**A>**) will be displayed on the screen. Type **DIR** and press the return key to display the **DIR**ectory of files available to use. The following will be displayed on the screen:

## OCC-1 DIAGNOSTIC DISKETTE

|    |        |       |        |     |
|----|--------|-------|--------|-----|
| A: | COPY   | COM : | PIP    | COM |
| A: | VIDEO  | COM : | BRUN   | COM |
| A: | SPEED  | COM : | MENU   | COM |
| A: | SYSGEN | COM : | STDKB  | DAT |
| A: | SETUP  | COM : | KB     | COM |
| A: | PRINT  | COM : | AUTOST | COM |

Some of these files can be used for testing while others are "utilitites" for specific functions. The **COPY** file can be used to copy entire diskettes or to format diskettes. To use this program type, **COPY** and press the RETURN key. The file will load and the screen will display the format and copy options. By entering **C** (copy) or **F** (format) you can select either program. Use caution and read the directions carefully when copying or formatting diskettes. Always write-protect the source diskette to prevent accidental erasing. When the format option is run an **\*** will be displayed on the screen as each track is formatted. If an error occurs on a track, **E** will be displayed on the track position where the error occurred and **FORMAT ERROR** will be displayed on the screen. In the **COPY** mode each track number is displayed as it is read from the source diskette and copied onto the destination. If an error occurs **COPY ERROR** will be displayed on the screen.

Press RETURN to exit the program. The prompt will be displayed. Type **DIR** to again display the **DIR**ectory. The next file name is **VIDEO**. When this is typed and the RETURN key is pressed a "burn-in" test pattern is displayed on the screen. This test pattern can be used to adjust centering or focus of the CRT. Refer to the Osborne Field Service Manual for the adjustments to the 5" CRT. Press and hold the CTRL key and press the **C** key to exit this test and reload the operating system to display the CP/M prompt (**A>**). Type **DIR** to display the **DIR**ectory.

The next file name is **SPEED**. This file allows you to display the diskette drive speed (A or B) on the CRT. This should only be used for a check of the speed and not adjustment. The **DISK EXERCISER** test within the Confidence tests should be used for the adjustment as this is the only test that allows you to seek to track 16 before the speed is verified or adjusted. The speed should always be set when the head is at track 16. Press and hold the CTRL key and press the **C** key to exit this test and reload the operating system to display the CP/M prompt (**A>**). Type **DIR** to display the **DIR**ectory.



## OCC-1 DIAGNOSTIC DISKETTE

The **SYSGEN** file is the name of the Operating System Generation Program. It is used to copy the operating system (only) from one diskette to another. Prevent accidental damage to your source diskette by applying a write-protect tape strip before you start this program. The screen will ask you to input which drive contains the source and the destination diskettes. When the procedure is completed "System copied successfully" will be displayed on the screen. Press the RETURN key to again display the system prompt.

The **SETUP** program is used to change the system configuration on a diskette with the operating system contained. When **SETUP** is entered and the RETURN key is pressed the screen will respond with "Which Diskette do you want to configure". The diskette drive that contains the operating system is the selection you should enter. When you enter the drive letter the configuration options will be displayed on the screen. This allows you to change the following:

Type of printer connected.

Baud rate required.

The size of the screen in characters.

Enabling of automatic horizontal screen scrolling.

Indicate a specific input for use with the function keys (CTRL + 0-9).

The use of the arrow keys.

Select the changes by inputting the letter of the item you wish to change and the options will be displayed. When you have finished with the changes press the X key to exit. The screen will request you to indicate which drive you want this information copied to. When you enter the letter (A, B, or X) the configuration will be copied and the system prompt will be displayed. Enter DIR to display the DIRectory.

The **PRINT** file is a very short Parallel Port Test which is not implemented in this version of the diagnostics. Use the Parallel Port test within the Confidence test to verify correct operation of the IEEE-488 circuits.

## OCC-1 DIAGNOSTIC DISKETTE

The **PIP** file (Peripheral Interchange Program) is used to copy a file to another diskette or other device (printer, modem). Type **PIP** and press the **RETURN** key. The following will be displayed to let you know the **PIP** program is available for use:

\*

To copy a file from diskette drive A to B you would enter the following:

B:file name.file name extension=A:file name.file name extension

When the **RETURN** key is pressed the file would be copied from drive A to drive B. Use caution when using the **PIP** program. Files can be written over if you have not input the correct sequence. Write-protect the source diskette to prevent accidental damage. To exit the **PIP** program and return to the prompt, press the **RETURN** key. The prompt (**A>**) will be displayed on the screen.

The **BRUN** file is a **CP/M** program which is not used for troubleshooting or utility purposes.

When **MENU** is typed and the **RETURN** key is pressed, the Confidence test main menu will again be displayed. You can use this file to enter the Confidence tests from the system prompt.

The **STDKB** file contains the information used to display the instructions for the keyboard test (**KB**). **STDKB** cannot be accessed for our use.

To use the keyboard test, type **KB** and press the **RETURN** key. The screen will sequentially display all of the characters (upper and lower) on the keyboard. You are asked to press the key displayed. If the wrong key is pressed an error will be displayed. As you press each key the screen will ask you to press the next until all are checked. When this is complete the screen will display **KEYBOARD GOOD**. Press the **ESC** key to again display the system prompt.

The last file is **AUTOST**. This file is not for troubleshooting purposes and is used to automatically load the Confidence test when you power the system on, insert the Diagnostic Diskette and press the return key.

## **. OCC-1 DIAGNOSTIC DISKETTE**

The procedures listed are to assist you in troubleshooting the Osborne OCC-1 Computer. You should refer to the Osborne Field Service Manual for procedures required for troubleshooting, removal/replacement, adjustments or Theory of Operation. Contact the XSB Technical Support Center in Dallas if you have any questions.



**OCC DIAGNOSTICS**

**OSBORNE COMPUTER CORPORATION  
EXECUTIVE COMPUTER DIAGNOSTIC PROCEDURES**



# OCC EXECUTIVE DIAGNOSTIC DISKETTE

## INTRODUCTION

The Osborne Field Service Department Executive Diagnostic Diskette is a menu driven diagnostic software package for Service Center Technician use in troubleshooting and verifying correct operation of the Osborne (OCC) Executive Computer. This diagnostic was used by Osborne in their Field Service, Manufacturing, Quality Assurance, and Engineering departments.

The Executive Diagnostic Diskette contains tests which are capable of exercising the following Executive components:

- Logic PWB
- Memory PWB
- Floppy Diskette Drives
- Keyboard

The Executive Diagnostic also has the capability of displaying various CRT test patterns to assist you in aligning the video presentation.

CP/M is also contained on the Executive Diagnostic Diskette which allows use of the following files:

- MBASIC (\* BASIC-80 programming language)
- SHOW (diskette space available)
- PIP (peripheral interchange program)
- COPY (copy or format diskettes)
- SDDBIT (diskette drive bit error rate check)
- SPEED (diskette drive timer & seek tests)
- CONTEST (confidence test)
- SETUP (configuration program)

The Executive Diagnostic is not designed as a "chip level" troubleshooting tool. To expedite repair the diagnostic will display a failure when it occurs, to one of the field replaceable units (Logic PWB, Memory PWB, Floppy Disk Drive, or Keyboard).

\* BASIC-80 (CP/M Version) is a registered copyright of Microsoft, Inc.

# OCC EXECUTIVE DIAGNOSTIC PROCEDURES

## PROCEDURES

Press the Power On/Off button to apply power to the Executive Computer.

When the screen displays "INSERT DISK IN DRIVE A AND PRESS RETURN" insert the Executive Diagnostic Diskette into drive A (upper diskette drive) and press the RETURN key.

As the diagnostic software is loaded various screens will be displayed on the CRT. When the diagnostic has completed loading the "Complexity Select" screen will be displayed. This screen is similar to the following:

### Complexity Select

```
>  Beginner (Field Service)
   Intermediate (Manufacturing)
   Advanced (Engineering)
   Expert (Debug)
   Exit to CP/M
```

Use ARROW KEYS to select appropriate complexity level  
Press RETURN key when ready to continue

The Executive Diagnostic Diskette can be used in different levels of troubleshooting. Each consecutively higher level (Intermediate, Advanced, Expert) is more complex in its testing although it contains the tests from the previous level (in this diagnostic version the Advanced and Expert levels are the same).

Service Center Technicians should only use the **EXPERT** level. This will allow you to utilize all available diagnostic capabilities.

To select the "Expert" complexity level, press the down arrow key until the "Expert" level is highlighted as shown below.

```
Beginner (Field Service)
Intermediate (Manufacturing)
Advanced (Engineering)
> Expert (Debug)
  Exit to CP/M
```



## OCC EXECUTIVE DIAGNOSTIC PROCEDURES

Press the RETURN key to enter this selection.

The next screen displayed is for "Test Configuration" options and appears similar to the following:

### Test Configuration

|                                 |                           |             |                      |
|---------------------------------|---------------------------|-------------|----------------------|
| <b>Test Type:</b>               | <b>Quick</b>              | <b>&gt;</b> | <b><u>Normal</u></b> |
| <b>Run Tests Using Disks?</b>   | <b><u>Test Drives</u></b> |             | <b>No Drives</b>     |
| <b>Diskette Type:</b>           | <b><u>Blank</u></b>       |             | <b>Formatted</b>     |
| <b>Run Loopback Plug Tests?</b> | <b><u>Plugs</u></b>       |             | <b>No Plugs</b>      |
| <b>Run Interactive Tests?</b>   | <b><u>Keys</u></b>        |             | <b>No Keys</b>       |

Use ARROW KEYS to select desired configuration  
Press RETURN key when ready to continue

Selection of the "Normal" type of test indicates the standard version of the test is to be run. The "Quick" test is a shorter version of the "Normal" test. You may not see any difference in time by running the quick version of a test. The software is designed to decrease the tests run in the "Quick" version but, not necessarily the time. This selection should be set to "Normal" to gain maximum benefit from the diagnostic test.

"Run Tests Using Disks?" offers you the ability to run diagnostics on the diskette drives. You may want to only verify the Logic PWB of computer unit in which case you would select "No Drives" and all diskette drive tests would be skipped. Either blank or pre-formatted diskettes can be used for testing purposes. Selection of the "Blank" option will cause the diskettes in both drives to be automatically formatted prior to the first drive test. If the "Formatted" option is selected the drive will not format the diskettes before the tests start.

To test the "MODEM RS232C", "PRINTER 232C", and "IEEE 488" ports on the Executive Computer, diagnostic loopback plugs must be placed on the connectors on the front bezel. If you do not want to run the tests on these ports or the loopback plugs are not available the "No Plugs" option should be selected on the "Run Loopback Plug Tests?" line. Failure to install the loopback plugs with "Plugs" option selected will cause a failure when the diagnostic test is run.

## OCC EXECUTIVE DIAGNOSTIC PROCEDURES

The two loopback plugs appear similar to the following:

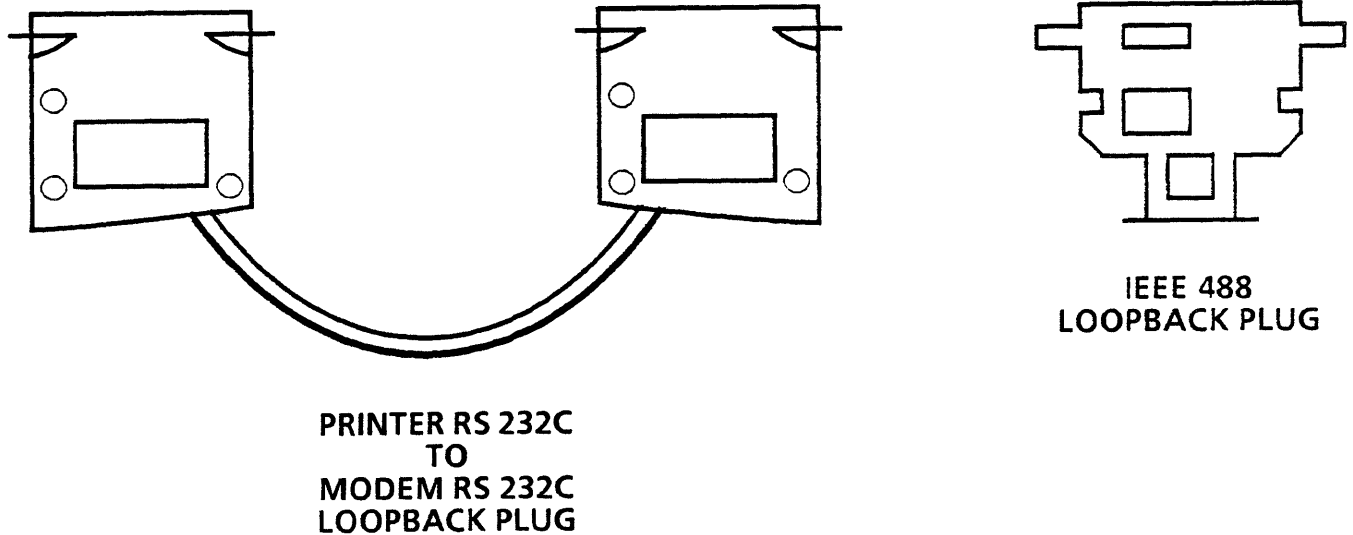

Insert the IEEE 488 loopback plug into the IEEE 488 port connector located below the floppy diskette drives.

Examine the connectors on the ends of the Modem/Printer RS 232C loopback plug. One connector has eight pins while the other connector has twelve pins. The connector with twelve pins should be plugged into the Modem RS 232C port. The connector with eight pins should be plugged into the Printer RS 232C port. A diagnostic failure will occur if they are reversed.

The last selection on the "Test Configuration" screen is "Run Interactive Tests?". The Keyboard and Screen tests require the user to press a key on the keyboard to allow the test to continue. There may be occasions when you do not want to interact with the keyboard to allow the diagnostics to run for an extended period of time. Selecting the "No Keys" option bypasses the keyboard and CRT display tests.

To change any option on the "Test Configuration" screen use the arrow keys (up, down, left, or right) to move the cursor (>) in front of the option you want selected. When you have completed selecting options press the RETURN key to enter the configuration into the system.

If you have selected options to test the diskette drives and run the loopback tests the following message will be displayed on the screen:

## OCC EXECUTIVE DIAGNOSTIC PROCEDURES

**"Remove all diskettes from disk drives  
Insert BLANK diskettes into disk drives  
and  
Place loopback plugs onto all connectors**

**Press RETURN key when ready to continue"**

Slightly different messages will be displayed if you have made any of the following changes to the "Test Configuration" screen:

Loopback plugs and no drive tests

Drive tests with blank or formatted diskettes and no loopback plugs.

To continue with the diagnostic process the Executive Diagnostic Diskette should be removed from diskette drive A and blank floppy diskettes should be inserted into drive A & drive B. Insert the IEEE 488 and Modem/Printer RS 232C loopback plugs into the appropriate connectors. Press the RETURN key when you have completed these steps.

When you enter the configuration selections (by pressing the RETURN key) the "Command Menu" will be displayed. This menu appears similar to the following:

| Osborne Executive System Test XX.XXX |                    | COMMANDS                   |
|--------------------------------------|--------------------|----------------------------|
| <b>MODULE</b>                        | <b>≥</b>           | <b><u>Run Once</u></b>     |
| <b><u>All</u></b>                    |                    | <b>Run Forever</b>         |
| <b>Logic Board</b>                   |                    | <b>Run Until Failure</b>   |
| <b>Memory Board</b>                  |                    | <b>Turn Test Off</b>       |
| <b>Drive A</b>                       |                    | <b>Turn Test On</b>        |
| <b>Drive B</b>                       |                    | <b>Test Summary</b>        |
| <b>Screen</b>                        |                    | <b>Print Test Summary</b>  |
| <b>Keyboard</b>                      |                    | <b>Test Configurations</b> |
|                                      |                    | <b>Complexity Select</b>   |
|                                      |                    | <b>Exit to CP/M</b>        |
|                                      |                    | <b>AVAILABLE KEYS</b>      |
|                                      |                    | <b>Arrow Keys</b>          |
|                                      | <b>&lt;- -&gt;</b> | <b>Select Options</b>      |
| <b>00000 Failures in</b>             |                    | <b>RETURN Performs</b>     |
| <b>00000 Attempts</b>                |                    | <b>Commands</b>            |
|                                      | <b>TAB</b>         | <b>More Screens</b>        |

## OCC EXECUTIVE DIAGNOSTIC PROCEDURES

The "MODULE" section of this screen lists the devices which can be diagnosed. You can highlight a test, which selects the test, by using the arrow keys. "ALL" tests can be selected to be consecutively or an individual test can be run separately.

If you highlight (select) an individual module such as the Logic Board, the screen will display the tests which can be run for that device. The "MODULE" section of the screen would appear similar to the following:

|   | <b>MODULE</b>      | <b>TEST</b>       |
|---|--------------------|-------------------|
|   | <u>ALL</u>         | <u>ALL</u>        |
| > | <u>Logic Board</u> | Serial Port Test  |
|   | Memory Board       | IEEE488 Port Test |
|   | Drive A            | Video Ram         |
|   | Drive B            | Attribute Rom     |
|   | Screen             | Rom's Ram         |
|   | Keyboard           | Rom               |
|   |                    | Bank Uniqueness   |

These are the tests which can be run for the Logic Board. The tests for each module are different. If we selected the Memory Board the test list would appear similar to the following.

|   | <b>MODULE</b>       | <b>TEST</b>   |
|---|---------------------|---------------|
|   | <u>All</u>          | <u>All</u>    |
|   | Logic Board         | Main Rom Test |
| > | <u>Memory Board</u> |               |
|   | Drive A             |               |
|   | Drive B             |               |
|   | Screen              |               |
|   | Keyboard            |               |

By using the arrow keys, you can select the option to run all of the individual test or any specific test.

At the bottom of the "MODULE" section the following is displayed:

**00000 Failures in**  
**00000 Attempts**

The "Failures" line will display the number of times an error occurs while you are running a test.

## OCC EXECUTIVE DIAGNOSTIC PROCEDURES

The "Attempts" line will display the number of times the test has been run. This count is accumulative and can only be cleared by exiting the diagnostic tests or by you clearing the count.

The next section of the "Command Memu", which is titled "COMMANDS", displays the options for running the test(s) you have selected. This portion of the screen appears similar to the following:

### COMMANDS

```
> Run Once
  Run Forever
  Run Until Failure
  Turn Test Off
  Turn Test On
  Test Summary
  Print Test Summary
  Clear Summary
  Test Configurations
  Complexity Select
  Exit to CP/M
```

"Run Once" selected will cause the test(s) you have chosen to run one time.

"Run Forever" selected will cause the test(s) you have chosen to run until the ESCape key is pressed. During many of the tests the keyboard is locked out and the computer will not respond until the test has concluded. To stop a test in the "Run Forever" mode you may have to press and hold the ESCape key until the test attempts to restart. At that time the keyboard input will be recognized and the test will stop. The tests you selected will continue to run in this mode even though a failure has been detected. This selection is especially useful for troubleshooting computers with intermittent problems.

The next selection, "Run Until Failure", will allow the testing to run continuously until a failure occurs. At the time of the error testing will stop and a failure indication will be displayed on the screen.

The "Turn Test Off" option is used to de-select tests you do not wish to run. The tests which can be run for the Logic Board are similar to the following:

## OCC EXECUTIVE DIAGNOSTIC PROCEDURES

|   | MODULE             | TEST              |
|---|--------------------|-------------------|
|   | ALL                | <u>ALL</u>        |
| > | <u>Logic Board</u> | Serial Port Test  |
|   | Memory Board       | IEEE488 Port Test |
|   | Drive A            | Video Ram         |
|   | Drive B            | Attribute Ram     |
|   | Screen             | Rom's Ram         |
|   | Keyboard           | Rom               |
|   |                    | Bank Uniqueness   |

If you wanted to de-select the "Serial Port Test" from running you would first press the arrow keys to select (highlight) the "Turn Test Off" option. Again use the arrow keys to highlight (select) the "Serial Port Test". When the RETURN key is pressed the screen will appear similar to the following:

|   | MODULE             | TEST                   | COMMANDS             |
|---|--------------------|------------------------|----------------------|
|   | All                | All                    | Run Once             |
|   | <u>Logic Board</u> | <u>S.... P... T...</u> | Run Forever          |
| > | Memory Board       | IEEE488 Port Test      | Run Until Failure    |
|   | Drive A            | Video Ram              | <u>Turn Test Off</u> |
|   | Drive B            | Attribute Ram          | Turn Test On         |
|   | Screen             | Rom's Ram              | Test Summary         |
|   | Keyboard           | Rom                    | Print Test Summary   |
|   |                    | Bank Uniqueness        | Clear Summary        |
|   |                    |                        | Test Configuration   |
|   |                    |                        | Complexity Select    |
|   |                    |                        | Exit to CP/M         |

If you wanted to select only the IEEE488 Port Test to run for the Logic Board you would first select the "Turn Test Off" option. Select "All" under the "Test" options and press the RETURN key. All of the tests are now de-selected. To select the IEEE488 Port Test to run, select the IEEE488 test then select the "Turn Test On" option. When you press the RETURN key only the IEEE488 test will be selected to run and the screen will appear similar to the following:

|   | MODULE             | TEST                   | COMMANDS             |
|---|--------------------|------------------------|----------------------|
|   | All                | All                    | Run Once             |
|   | <u>L.... B....</u> | <u>S.... P... T...</u> | Run Forever          |
| > | Memory Board       | IEEE488 Port Test      | Run Until Failure    |
|   | Drive A            | V.... R..              | <u>Turn Test Off</u> |
|   | Drive B            | A..... R..             | Turn Test On         |
|   | Screen             | R.... R..              | Test Summary         |
|   | Keyboard           | R..                    | Print Test Summary   |
|   |                    | B... U.....            | Clear Summary        |
|   |                    |                        | Test Configuration   |
|   |                    |                        | Complexity Select    |
|   |                    |                        | Exit to CP/M         |

## OCC EXECUTIVE DIAGNOSTIC PROCEDURES

To turn all tests back on select the "All" option under the "TEST" column, and the "Turn Test On" option under the "COMMANDS" column. When the RETURN key is pressed all tests will be available for use.

The next selection under the "COMMANDS" column is "Test Summary". If the "All" selection under the "MODULE" column and the "Test Summary" under the "COMMANDS" column is selected, the following will be selected when the RETURN key is pressed:

### Osborne Executive System Test XX.XXX

|              | Failures | Attempts | Error Rate |
|--------------|----------|----------|------------|
| Logic Board  | 00000    | 00000    | 000%       |
| Memory Board | 00000    | 00000    | 000%       |
| Drive A      | 00000    | 00000    | 000%       |
| Drive B      | 00000    | 00000    | 000%       |
| Screen       | 00000    | 00000    | 000%       |
| Keyboard     | 00000    | 00000    | 000%       |

Press RETURN key when ready to continue

The "Test Summary" is a listing of the number of failures, number of attempts to run a test, and the rate at which failures occurred while testing each specific module. If a specific module was selected, such as the Logic Board instead of "All", the screen would have only displayed the summary for the Logic Board. If a failure was detected the name of the failing test under the name of the module as well as the summary data would be displayed. The following is an example of a test summary for a test run on the Logic Board in which the IEEE488 Port Test failed three of the four times it was run:

### Osborne Executive System Test XX.XXX

|                                 | Failures | Attempts | Error Rate |
|---------------------------------|----------|----------|------------|
| Logic Board                     | 00003    | 00004    | 075%       |
| FAILING TEST:<br>IEEE Port Test | 00003    | 00004    | 075%       |
| Memory Board                    | 00000    | 00000    | 000%       |
| Drive A                         | 00000    | 00000    | 000%       |
| Drive B                         | 00000    | 00000    | 000%       |
| Screen                          | 00000    | 00000    | 000%       |
| Keyboard                        | 00000    | 00000    | 000%       |

## OCC EXECUTIVE DIAGNOSTIC PROCEDURES

If you wanted a print-out of this summary, you would select the next option in the "COMMANDS" list which is "Print Test Summary". The test summary data would be sent to the printer connected to the printer port when the RETURN key was pressed. Before selecting this test ensure the printer is properly connected and the computer is set correctly for the type of printer you are using (refer to the SETUP CP/M utility file).

The next option "Clear Summary" is used to erase the "Test Summary" data. As diagnostic tests are run the error information is updated in the summary. To clear this information the "Clear Summary" option would be selected and the RETURN key pressed. The summary is also cleared each time the computer is powered off or the reset button is pressed.

By selecting the "Test Configuration" option and pressing the RETURN key the "Test Configuration" screen will again be displayed. This gives you the opportunity to change the configuration for any test combinations you choose.

The "Complexity Select" option allows you to return to the "Complexity Selection" screen to change the level of diagnostics. All testing should be accomplished in the **EXPERT** mode only.

The last option, "Exit to CP/M", allows you to exit the diagnostic routines and use the available CP/M files. We will use these files shortly.

The lower right corner of the screen contains information on the available keys which can be used for directing the diagnostic routines. The arrow keys are used to move from column to column in the horizontal and vertical directions. The RETURN key is pressed to start the computer performing the command selected. When the TAB key is pressed a series of four screens are displayed (one each time the tab key is pressed) which show information on the way the diskette drives performed under diagnostic test.

The first screen is the "Total Sectors Read Report". It displays the double and single density total sectors read & total read errors for drives A and B.



## OCC EXECUTIVE DIAGNOSTIC PROCEDURES

The second screen lists a "Single Density Sector Count" for drives A and B. The first column, "TRK", indicates the track number on each diskette. The second column, "READS", indicates the number of sectors read. The third column, "ERRORS", indicates the number of errors which occurred. There is a listing for each track of each diskette.

The third screen displays the same information as the previous screen but in a double density test mode rather than single density.

The last screen is the "DOUBLE DENSITY BAD SECTOR MAP". This display shows the position of bad sectors which have been found during testing. A bad sector will be indicated by the letter **B** (Bad) on one of the lines corresponding to a track and sector position.

If a diskette drive is operating marginally you may find bad sector errors (B) on the inner tracks (past track 30) more than on the outer tracks (starting at 0). Diskette drives pack data more densely on the inner than the outer tracks and so the drive operation becomes more critical.

If you are monitoring these displays while tests are running, press the space each time you want to update the data on the screen.

To run a complete pass of all diagnostic tests the following selections should be entered:

Complexity Select

**Expert**

Test Configurations

**Normal test type**

**Test Drives**

**Blank diskette type**

**Plugs (loopback) installed**

**Keys (for interactive tests)**

Insert blank diskettes into the drives and loopback plugs on the connectors.

MODULE

Select **All**

COMMANDS

Select **Run Once**

Press the RETURN key to start the diagnostic test.

## OCC EXECUTIVE DIAGNOSTIC PROCEDURES

To indicate the test which is running a + sign is placed before the name of the module and test in progress. The name of the test and track and sector information, if a diskette drive test is running, is also displayed on the bottom of the screen.

While the diskette drive tests are running press the tab key to monitor the screens for diskette drive data. Press the space bar each time you want to update the information on the screen. Press the tab key until you return to the "Command Menu" screen before the diskette drive tests complete.

When the diskette diagnostic is completed the Screen diagnostic test starts. The Screen diagnostic is comprised of four alignment patterns displayed on the CRT.

The first pattern displayed is a "Border Pattern" which should be used to assure that the screen size is adjusted properly.

When the RETURN key is pressed again the second pattern will be displayed. This pattern is a display of horizontal lines across the screen.

Press the RETURN key once again and the third pattern will be displayed. This pattern fills the screen with vertical lines.

The last pattern is displayed when the RETURN key is again pressed. A "Cross Hair" pattern is displayed which can be used to adjust the screen horizontal centering, vertical centering, and focus. Refer to the Osborne Field Service Manual for the adjustment procedures for the "Zenith 7 Monitor".

When the RETURN key is again pressed the Keyboard diagnostic test will start. The screen will display each key on the keyboard in sequential order. As each correct key is pressed the next sequential key will be displayed. When the test passes successfully the following message will be displayed.

**KEYBOARD GOOD**  
**Press RETURN to Test another Keyboard**  
**Press ESC to QUIT**

## . OCC EXECUTIVE DIAGNOSTIC PROCEDURES

With the Keyboard test completed all of the diagnostic tests have been run.

Select the "Test Summary" of the "COMMANDS" section and press the RETURN key to display the summary. If all tests passed without error the summary should indicate 0 Failures, 1 Attempt with an Error Rate of 0%.

To simulate an error condition during a diagnostic test unplug the IEEE488 loopback plug from the connector and select the following on the command menu.

|          |          |
|----------|----------|
| MODULE   | All      |
| TEST     | All      |
| COMMANDS | Run Once |

When you press the RETURN key the diagnostic test will start.

The + symbol is displayed as each test runs. When the diagnostic test for the IEEE488 Port Test starts the + symbol is displayed before the Module Logic Board and the IEEE488 Port Test. When the system encountered the failure a ? is placed before the module name and the name of the test. The name of the test and the word **FAILED** is also displayed at the bottom of the screen. Press the ESCape key to stop the test. Select the "Test Summary" and press the RETURN key. The Summary should indicate all tests were attempted at least once. The Logic Board test and the IEEE Port Test were attempted twice with one failure. The error rate is 50%. Errors will be maintained by the "Test Summary" to supply you with updated data about the performance of the computer.

The Executive Diagnostic Diskette is not intended for troubleshooting to the chip level. The modules displayed on the screen (Logic Board, Memory Board, Drive A, Drive B, Screen, and Keyboard) are the field replaceable parts. Do not discount the possibility of a power supply, wiring, or plug/jack problem with these devices. Refer to the Field Service Manual for removal/replacement, adjustment or troubleshooting procedures to assist you in repairing problems.

Now that we have seen the diagnostics run in a completed pass and failure mode, we will discuss each of the individual tests and determine what is verified.

## OCC EXECUTIVE DIAGNOSTIC PROCEDURES

Highlight (select) the Logic Board under the MODULE column. The Logic Board tests are displayed in the TEST column. A discussion of each of these tests follows:

### **Serial Port Test**

In this test serial full-duplex asynchronous data is sent between the MODEM and PRINTER RS232C ports on the front of the computer using the loopback plugs. Data is transmitted at 19,200 and 9600 baud between channel A and B of the Z80-SIO chip on the Logic Board. The synchronous modes of HDLC or SDLC are not tested.

The test takes approximately ten seconds to run. If the loopback plug is not connected or is faulty a failure will be displayed.

### **IEEE488 Port Test**

With a loopback plug connected to the IEEE488 port on the front of the computer the IEEE488 6821 chip on the Logic Board is verified. The test takes approximately one second to run.

### **VIDEO RAM TEST**

The Video Ram is located in bank seven and the test verifies the bank in two parts. The first part of the test checks each memory cell for stuck bits. The second part checks that different addresses point to unique memory cells.

### **ATTRIBUTE RAM**

The Attribute ROM is also located in bank seven and is verified by checking for stuck bits.

### **ROM'S RAM**

The ROM'S RAM resides in bank six and is verified by using the same tests as are used for the Video Ram.

### **ROM**

The ROM is located in bank eight. This is verified by a check sum test in which the data in the ROM is added and checked against a standard reference for validity.

## OCC EXECUTIVE DIAGNOSTIC PROCEDURES

### BANK UNIQUENESS

This test ensures that the process of writing to any bank of memory does not write to any of the other banks as well.

Highlight (select) the Memory Board under the MODULE column. The Memory Board test (Main RAM) is displayed in the TEST column. A discussion of this test follows:

The RAM on the Memory Board is in two different banks. Bank 0 is 64K and bank 1 is 60K. In this test the addresses are checked one by one and restored before continuing with the next one. This is accomplished by reading the data and saving it, writing a test to the RAM location, reading it back, and finally restoring the original data.

Highlight (select) DRIVE A under the MODULE column. The Diskette Drive tests are displayed in the TEST column. The tests for Drive A and Drive B are the same. A discussion of these tests follow:

If you have selected "BLANK DISKETTE TYPE:" on the test configuration screen, the first step to be performed is a format of the diskettes in drives A and B. The diskettes will be formatted in "DOUBLE DENSITY". Any drive or diskette errors occurring during format will not cause a failure to be displayed. The format routine will not be completed until all tracks on both diskettes are formatted correctly or the "ESC" key is pressed to abort the format. If you are only testing one of the drives (A or B) a diskette must be placed in each of the drives as both will initially be formatted. Read errors are recorded and bad sectors are indicated on the error screens. As each track is successfully formatted and read a \* is displayed below the track number on the format screen. If an error occurs in either the format or read operation the letter E will be displayed instead of the \* to indicate a failure has occurred. The format process will continue through each track of the diskette. Depending upon the number of errors encountered the format process may be restarted for the drive which displayed the errors.

If you have selected "FORMATTED DISKETTE TYPE:" under the test configuration list the format process will be skipped and the testing will start for the drive selected or drive A if testing is for both drives.

## OCC EXECUTIVE DIAGNOSTIC PROCEDURES

The first drive test is titled "READ IN". This test seeks to track 0 and then read all of the sectors on that track starting from sector 1. This process repeats for all of the tracks on the diskette. If an error occurs in any sector on a track the testing is halted for that track and the test starts at the next inner track. The corresponding bad sector which failed the test is recorded in the "BAD SECTOR MAP" and a read error will be displayed on the screen and logged in the "TEST SUMMARY". The "TOTAL SECTORS READ" will also increment by the number of valid sectors read.

The "READ OUT" tests performs the same routine as the "READ IN" test except that the test starts to read at track 39 and continues in descending (outer) order towards the 0 track. The same error reporting will occur.

The "WRITE IN" test is a sequential write and seek to the next track starting with track 0. Each sector is written. If a seek or write error is encountered the test is halted for that track and continues on the next. Errors will be listed in the "TEST SUMMARY" and displayed on the screen as they occur.

The "WRITE OUT" test is the same procedure as the "WRITE IN" test except the process of testing starts with track 39 and testing towards the outer tracks until track 0 is reached. Error reporting is the same as the previous test.

The next test listed is the "RANDOM SEEK AND READ" test. This test seeks to a random track between track 0 and 39 and reads all of the sectors on that track. The test continues with another random track selected between 0 and 39 until all of the tracks have been tested. If a seek error to the designated track occurs no read attempt is made. An error will be logged to the "TEST SUMMARY" and the "TOTAL SECTORS READ" will increment for all correctly read sectors.

The "RANDOM SEEK WRITE AND READ" test seeks to a random track between 0 and 39. The test then writes to all of the sectors and reads all of the sectors from that track. If a seek error occurs there is no attempt to write. The drive will attempt to seek eleven times before a final error is displayed. The "TOTAL SECTORS READ" and error counters are updated as each occurs.

## OCC EXECUTIVE DIAGNOSTIC PROCEDURES

The next drive test is the "SELECT RANDOM SEEK AND READ". This test turns the drive that is being tested off, selects the other drive, delays  $\frac{1}{4}$  of a second, then reselects the drive under test. A random seek to a track between 0 and 39 is performed and a read of that track occurs. This process occurs until all of the tracks have been read. The "SECTORS READ" and error counters will be updated during testing.

"ACCORDION SEEK AND READ" is the next test listed. In this test a seek is performed from track 0 to track 39, 1 to 38, 2 to 37, etc. As each track is reached all sectors are read. Once the first pass of this test completes the test starts again in reverse order from track 20 and seeks towards the outer tracks of the diskette. The "SECTORS READ" and error counters will be updated during testing.

The last diskette drive test is the "SHORT SINGLE DENSITY TEST". In this test tracks 16 and 31 are formatted in single density. The tracks are written and then read. The tracks are then reformatted in double density. The "SECTORS READ" (Single Density) and error counters will be updated during testing.

The next set of module tests display various test patterns for alignment and verification of screen functions.

The "BORDER PATTERN" is a cleared screen with a border around the edge. This is used to ensure the screen size is adjusted properly.

The "HORIZONTAL LINES" pattern is a screen filled with horizontal lines. This is accomplished by clearing the screen and enabling the underline function to be used to create the lines.

The "VERTICAL LINES" pattern is used to fill the screen with vertical lines. There is no vertical line character and so one has been defined and used as a character font from the graphics character set.

The "CROSSHAIR PATTERN" is a single vertical and horizontal line both positioned to intersect at the center of the screen. This pattern is also used for alignment purposes.

## OCC EXECUTIVE DIAGNOSTIC PROCEDURES

The last test under the MODULE column is the "KEYBOARD TEST". The screen prompts the user to press specific keys. If an incorrect key is pressed "ERROR" will be displayed on the screen, the letter pressed will be listed, and the key which should have been pressed will be displayed. If a key is malfunctioning the screen will not change to the next key when pressed.

Highlight (select) the following:

|          |              |
|----------|--------------|
| MODULE   | ALL          |
| COMMANDS | Exit to CP/M |

Remove the diskette from drive A. Insert the "Osborne Field Service Department Executive Diagnostic Diskette", close the door, and press the RETURN key to load CP/M. When CP/M is loaded A> will be displayed on the screen. Type DIR and press the RETURN key. The following files will be displayed on the screen from the CP/M DIRectory:

|        |         |        |         |       |
|--------|---------|--------|---------|-------|
| EXECST | PIP     | COPY   | CONTEST | SETUP |
| MB     | SINE    | SDDBIT | DDBIT3  | DIR   |
| SHOW   | COPYSYS | SPEED  |         |       |

The following is a discussion of each of these files:

"EXECST" is the file name of the diagnostic tests we have just discussed. If you wanted to return to the diagnostic tests from this directory, type the file name and then press the RETURN key. The test will load and the "Complexity Select" screen will be displayed.

"MB" is the file name for MBASIC. When this file name is typed and the RETURN key is pressed the following will be displayed on the screen:

```
BASIC-80 Rev. 5.21
[CP/M Version]
Copyright 1977-1981 (C) by Microsoft
Created 29-May-81
XXXXXX Bytes Free
OK
```



## OCC EXECUTIVE DIAGNOSTIC PROCEDURES

"OK" is the prompt in BASIC and tells you the program is ready for your input. At this time you could enter a program in BASIC or return to the DIRectory. To exit MBASIC and return to the DIRectory type, **SYSTEM** and press the RETURN key. The prompt (A>) will be displayed on the screen to let you know CP/M has loaded. Type DIR and press the RETURN key to again display the directory.

The "SHOW" file will display the space available on the diskette which contains the file (similar to the STAT file of the 820). Enter SHOW and press the RETURN key. The screen will display the available space similar to the following:

**A: RW, Space:      XXK**

The XX would indicate the amount of space available on the diskette for storage.

The next file is the "PIP" or Peripheral Interchange Program. "PIP" is used to copy a file from one disk to another, or to another peripheral (printer, modem) device. Type PIP and press the RETURN key. The following will be displayed to let you know the PIP program is available for use:

**CP/M 3 PIP Version 3.0**

\*

To copy a file from diskette drive A to B you would enter the following:

**B:file name.file name extension=A:file name.file name extension**

When the RETURN key was pressed the file would be copied from drive A to drive B. Use caution when using the PIP program. Files can be written over if you have not input the correct sequence. To exit the PIP program and return to the prompt, press and hold the CTRL key and then press the C key. The prompt (A>) will be displayed on the screen to let you know CP/M is available.

The next file name listed is "SINE". "SINE" is a program, written in MBASIC, which will display a vertically moving sine wave on the screen. To run the program enter the following:

**MB SINE.BAS**

## OCC EXECUTIVE DIAGNOSTIC PROCEDURES

When the RETURN key is pressed the "SINE" program will start and you will see a series of \* scrolling across the screen.

Depending upon the type of diskette the files have been copied onto (with or without a write protect cutout) one of the following may be displayed on the screen:

If the diskette does not contain a write protect cutout the sine will make approximately four sweeps on the diaplay and the following message will appear:

```
SAVING SINE  
BIOS error writing drive A: write-protected,  
Retry this operation? (Y or N)?
```

Because this diskette is write-protected this error occurred. Press the **RESET** button on the Executive Computer and then press the RETURN key. The diskette will load and the "Complexity Select" screen will be displayed. Highlight (select) "Exit to CP/M" and press the RETURN key. Enter DIR after the prompt (A>) to again display the DIRectory.

If the diskette does contain a write-protected cutout and the write-protect tape is not taped to the cutout the program will react differently. The sine will sweep approximately four times and the screen will display "SAVING SINE LOADING SINE". This process will continue until the CTRL key is held down and the C key is pressed. The screen will return to the BASIC prompt (OK). When SYSTEM is entered and the RETURN key is pressed the system prompt (A>) will be displayed.

Enter DIR to again display the DIRectory. The "COPYSYS" file is used to copy the system files from one diskette to another. When COPYSYS is entered and the RETURN key is pressed the screen will display the following:

```
Get System from Drive A  
Get System from Drive B  
Return to CP/M
```

If the drive A or drive B options are selected and the RETURN key is pressed, the system files are read from the diskette and placed into memory. The screen will respond with instructions to save the options.

## OCC EXECUTIVE DIAGNOSTIC PROCEDURES

When the RETURN key is again pressed the system files can be copied onto drive A or drive B. You also have the option to Return to CP/M without saving the system files.

If we return to CP/M and display the directory (DIR) the next files name is "COPY". The "COPY" program is used to copy the contents of an entire diskette to another or format a diskette. When COPY is typed and the RETURN key is pressed the following will be displayed on the screen:

**Disk Utility Program  
Osborne Executive Computer System  
V1.1**

**Copy Diskettes  
Format Diskettes  
RETURN to CP/M**

**Use the ARROW keys to position the  
cursor next to the desired choice  
or  
Press RETURN to select a COPY option**

If the COPY option is selected you are given the choice to copy from drive A to drive B or drive B to drive A. You are also directed to insert the diskette and press the RETURN key when you want to start copying.

If FORMAT DISKETTES is selected and the RETURN key is pressed the screen will respond with the options of formatting the diskette in drive A or drive B. You can also return to the MAIN MENU (COPY, FORMAT, EXIT) or return directly to CP/M.

When using either the COPY DISKETTE or FORMAT DISKETTE programs ensure you indicate the correct drive for the action you want to happen. This will avoid accidental damage if an important diskette is in the unit.

The "SDDBIT" program is a diskette drive error rate test. "SDDBIT" reads the contents of each track and informs you of read errors which have occurred. When this test is loaded (by typing SDDBIT and then pressing the RETURN key) and a drive is selected, either A or B, the drive selected will start the test. The diskette is read to determine the density of recording. This is displayed on the screen with the numbers of sectors in each track.

## OCC EXECUTIVE DIAGNOSTIC PROCEDURES

The number of tracks read, errors which have occurred, the track number which is currently being read, and the word read (in hexadecimal) are also displayed. When the selected drive letter was pressed (A or B) the drive started to read at the current head location. Once the drive has read to track 39 the process will start over again at 0. This loop will continue until the CTRL key is pressed and held and then the C key is pressed. The test can also be looped on one track or a series of tracks. While the test is running press the first key of a track number between 0 and 39. The test will halt. When the second number is pressed to indicate the last digit of the selected track the test will again start but only read on that track. When the letter A is pressed the test will start to loop from the track you just selected to track 39.

The file listed in the directory "DDBIT3.DOC" also contains the procedures for running the SDDBIT program. To display this file on the screen (with the prompt (A>) displayed) enter, **TYPE DDBIT3.COM** and press the RETURN key. Each time you press the RETURN key more instructions will be displayed. If the screen scrolls too fast, press and hold the CTRL key and press the S key to stop the screen. When you want to restart the screen, press and hold the CTRL key and press the Q key. To exit this program to CP/M press and hold the CTRL key and press the C key. A> will be displayed to indicate CP/M is available.

The "SPEED" program is a set of operations which can be performed on the diskette drives. To display, type SPEED and press the RETURN key. The following blocks will be displayed:

|             |             |            |              |              |
|-------------|-------------|------------|--------------|--------------|
| <u>HOME</u> | <u>SEEK</u> | <u>ALT</u> | <u>DRIVE</u> | <u>DRIVE</u> |
| HEAD        | TRACK       | TRACK      | TIMER        | SELECT       |

---

|   |    |    |    |
|---|----|----|----|
| 0 | 10 | 20 | 30 |
|---|----|----|----|

The numbers below the blocks indicate tracks.

The **DRIVE SELECT** block is used to select the drive you wish to use (A or B). The RETURN key does not have to be pressed.

## OCC EXECUTIVE DIAGNOSTIC PROCEDURES

Use the arrow key to highlight the **SEEK TRACK** block. When the RETURN key is pressed the screen will respond with "**Enter new track number (0-39)**". Enter the number and when the RETURN key is pressed the drive will seek to the location you input. The indicator on the line of the screen will be placed at the selected track also.

The **DRIVE TIMER** is used to monitor the speed of the drive to verify correct speed and adjust if necessary. To run the DRIVE TIMER correctly a seek to track 16 should be performed first. With the head at track 16 use the arrow key to highlight the DRIVE TIMER block. When the RETURN key is pressed the speed in milliseconds is displayed in a box on the center of the screen. The correct speed for the ALPS drive in the Executive Computer is **200+1** milliseconds (VR1 on the spindle-motor control board should be adjusted to obtain this setting).

The **HOME HEAD** selection is used to move the head back to the home position. Use the arrow key to highlight the HOME HEAD block. When the RETURN key is pressed the head will move to home from its location. The indicator on the line of the screen will also indicate the home position.

The **ALT TRACK** selection is used to cycle the head from one track to another. Use the arrow keys to select the ALT TRACK block and press the RETURN key. The screen will respond with "**Enter new track number (0-39):**" When you enter the new number and press the RETURN key the head will alternate from the current track to the track you input. To change the current track use the SEEK TRACK block and then return to the ALT HEAD block.

Press and hold the CTRL key and press the C key to exit this program to return to the prompt A>.

Type DIR to again display the DIRectory.

The "CONTEST" program is a diskette and computer "confidence test". The tests within "CONTEST" are the same tests you used earlier. In the "CONTEST" program they can be run sequentially or you can select an individual test to run. Enter CONTEST and press the RETURN key.

## OCC EXECUTIVE DIAGNOSTIC PROCEDURES

The test names are listed on the screen along with a column for the number of times the test has run and the number of errors which have occurred. The test options are also displayed on the right side of the screen. To select a test option the letter is typed instead of highlighting (selecting) the option by the use of the arrow keys. With the cursor next to the "ALL NON-INTERACTIVE TESTS" selection press the **R** key. All of the tests from DRIVE A to the IEEE488 test will automatically be run. If you want to run one of the interactive tests, such as the KEYBOARD TEST, use the arrow keys to move the cursor in front of the KEYBOARD TEST and press the **R** (Run Once) key. When the NON-INTERACTIVE TESTS are run a Disk Drive Error Screen will be displayed. This screen will show the number of errors which occurred for each diskette drive. If errors do occur while testing a diskette, the screen will flash **REJECT** when the test is finished. This indicates you have either a faulty diskette, drive, or control circuit.

To return to the prompt **A>** press the **X** key and then press the RETURN key.

Enter **DIR** to again display the DIRectory.

The "DIR" file is listed within the directory. DIRectory is the file name we have been using to display the files which are located on this diskette.

The "SETUP" file is used to make changes to the system configuration. By using this program and changing the system configuration you can connect the Executive to various types of peripheral devices for different applications. When SETUP is entered and the RETURN key is pressed the following will be displayed on the screen:

### Select source for configuration

```
FROM MEMORY
FROM DRIVE A
FROM DRIVE B
EXIT TO CP/M
```

If you had a different configuration on another diskette, the diskette would be inserted into either drive, the drive selected and the RETURN key pressed. The following would be displayed (this screen will also be displayed if you selected **FROM MEMORY**).

## OCC EXECUTIVE DIAGNOSTIC PROCEDURES

**\*\*\* Osborne Executive Configuration Program \*\*\***

**V1.1**

Select the items you want to change

Current Settings

**Key Definitions  
Console Parameters  
MODEM PORT  
PRINTER PORT  
PARALLEL PORT  
EXIT TO SAVE MENU**

The KEY DEFINITIONS allow you to change the functions of the 0-9 and arrow keys. You could then use these functions for special program applications.

The CONSOLE PARAMETERS can be changed to vary the cursor type, screen background, key click, monitor frequency, and initialization string (a set of commands which precedes a program and is used to set commands for proper operation).

The MODEM PORT configuration can be changed for the baud rate, protocol, device selection, and initialization string.

Changes can be made to the PRINTER PORT for baud rate, protocol, device selection, and initialization string.

PARALLEL PORT settings which can be changed include protocol, device selection, and initialization string.

Changes are made to these selections by using the arrow keys to move the cursor and then pressing the RETURN key to make the selection. Different selections are available for each of the items listed.

When the configuration is set, "EXIT TO SAVE MENU" is pressed. A screen is displayed to select the destination for the configuration to be saved. "MEMORY, DRIVE A, or DRIVE B" can be selected to use for saving the configuration changes. You can also return to the selections screens or exit directly to CP/M.

## OCC EXECUTIVE DIAGNOSTIC PROCEDURES

When the selection is made for the destination to save the configuration and the RETURN key is pressed "Configuration saved to (DRIVE A DRIVE B or MEMORY) will be displayed. Exit to CP/M would then be selected to return to the system prompt (A>).

The procedures listed are to assist you in troubleshooting the Osborne Executive Computer. You should refer to the Osborne Field Service Manual for procedures required for troubleshooting, removal/replacement, adjustments or Theory of Operation. Contact the XSB Technical Support Center in Dallas if you have any questions.





